

ENGLISH

**PS-800-12080
INSTRUCTION MANUAL**

CONTENTS

1. SPECIFICATIONS	1
2. CONFIGURATION	2
3. INSTALLATION.....	3
3-1. Setting up the sewing machine.....	3
3-2. Installing the air hose	9
3-3. Cautions for the compressed air supply (source of supply air) facility..	10
3-4. Installing the bobbin winder device	11
3-5. Precautions for installation of the machine.....	11
4. PREPARATION OF THE SEWING MACHINE	12
4-1. Lubricating method and check of the oil quantity	12
4-2. Attaching the needle	13
4-3. Threading the machine head.....	14
4-4. Bobbin replacement procedure	15
4-5. Adjusting the thread tension.....	16
4-6. Adjusting the thread take-up spring and the thread breakage detector plate.....	17
4-7. Adjusting the thread take-up stroke	17
4-8. Needle-to-hook relationship.....	18
4-9. How to wind a bobbin	20
4-10. Adjusting the needle bar height	21
4-11. Adjusting the position of the thread trimmer	22
4-12. How to attach / remove the cylinder lifting plate	24
4-13. How to confirm the amount of oil (oil splashes) in the hook.....	25
4-14. Adjusting the amount of oil in the hook	26
4-15. Adjusting the needle hole in the throat plate and the needle	27
4-16. Setting the mechanical origin.....	28
4-17. Adjusting the disk presser pressure.....	29
4-18. Adjusting the thread end position at the beginning of sewing	30
4-19. Adjusting the electronic intermediate presser stroke.....	31
4-20. Adjusting the needle thread air blower.....	32
4-21. Making a template.....	33
4-22. Preparation for sewing	35
4-23. Configuration of the operation panel.....	37
4-24. Maintenance mode.....	39
4-25. List of parameters.....	40
4-26. List of error codes	46

5. MAINTENANCE OF SAWING MACHINE	51
5-1. Troubles and corrective measures (Sewing conditions).....	56
5-2. Disposal of batteries	58
6. SUBCLASS MODEL.....	59
6-1. Barcode reader	59
6-2. Rotary knife.....	64
6-2-1. Safety precautions.....	64
6-2-2. How to carry out coaxial adjustment.....	65
6-2-3 How to adjust the timing belt tension.....	68
6-2-4 How to adjust he knife pressure	68
6-2-5. Changing the moving knife	72
6-2-6. Adjusting the operating speed of template when the knife operates	72
6-2-7. Usage instructions	73
6-2-8. Definition of the electrical control buttons	75
6-2-9. Function-related precautions	75

1. SPECIFICATIONS

1	Sewing area (X,Y)(mm)	1200 × 800 (Cutting area Rotary knife type : 698 × 391 Laser type : 646.5 × 426.5)
2	Feed motion of feeding frame	Intermittent feed (2-shaft drive by stepping motor)
3	Needle bar stroke	39.5 mm
4	Max. sewing speed	[S type] 3,000 sti/min (When stitching pitch is 2.2 mm or less) [H type] 1,800 sti/min (When stitching pitch is 3.5 mm or less) For other stitch pitches and numbers of revolutions, refer to Fig. 1.
5	Settable stitch length	0.5 to 12.7 mm
6	Needle	[S type] DB × 1 #8 (#7 to #14), DP × 5 #8 (#7 to #14) [H type] DP17 #21 To be chosen according to the model.
7	Hook	Double-capacity full-rotary hook
8	Intermediate presser stroke	4 mm (Standard)
9	Lift of intermediate presser	20 mm
10	Lift of disc presser	15 mm
11	Memory of pattern data	Max. 999 patterns
12	Number of patterns that can be identified	Max. 999 patterns
13	Program input method	USB
14	Data format	DXF.AI.PLT.DST
15	Main shaft servomotor power	[S type] 550W [H type] 750W
16	Power consumption	470VA
17	Input voltage	220V ± 10%
18	Mass (gross mass)	780 kg [Rotary knife type] 788kg [Laser type] 850kg
19	Dimensions	2,180 mm (W) × 2,185 mm (L) × 1,250 mm (H)
20	Operating temperature range	5 to 35 °C [Laser type] 1 to 35 °C
21	Operating humidity range	35 to 85 % (No dew condensation) [Laser type] 5 to 70 %
22	Storage temperature range	-5 to 60 °C [Laser type] -10 to 100 °C
23	Storage humidity range	20 to 85 % (No dew condensation, 85 % applies to the case where the temperature is 40 °C or lower) [Laser type] 20 to 85 % (No dew condensation)
24	Air pressure used	0.5 to 0.6 MPa
25	Needle highest position stop facility	After the completion of sewing, the needle can be brought up to its highest position.
26	Noise	- Equivalent continuous emission sound pressure level (L _{pA}) at the workstation : A-weighted value of 78.0 dB ; (Includes K _{pA} = 2.5 dB) ; according to ISO 10821- C.6.2 -ISO 11204 GR2 at 2,800 sti/min.
27	Lubricating oil	#10 (Equivalent to JUKI NEW DEFRIX OIL No. 1) #32 (Equivalent to JUKI NEW DEFRIX OIL No. 2), Lithium based grease No. 2 Grease information Manufacturer: WERATCHE Type and number: Lithium base 2# grease

S type

Stitch pitch and the sewing speed			
Number	Stitch pitch	Sewing speed	Remarks
1	2.8 mm	2,800 sti/min	
2	3.0 mm	2,500 sti/min	
3	4.0 mm	2,200 sti/min	
4	5.0 mm	1,800 sti/min	

Note: The sewing machine must not run at the maximum number of revolutions continuously for more than 15 minutes. The number of revolutions may vary even if the pitch is consistent due to the change in the needle and material.

H type

Stitch pitch and the sewing speed			
Number	Stitch pitch	Sewing speed	Remarks
1	3.5 mm	1,800 sti/min	
2	4.0 mm	1,600 sti/min	
3	4.5 mm	1,400 sti/min	
4	5.0 mm	1,200 sti/min	

Note: The number of revolutions may vary even if the pitch is consistent due to the change in the needle and material.

Fig. 1

2. CONFIGURATION



- ① Machine head
- ② Table
- ③ X-axis feed mechanism
- ④ Y-axis feed mechanism
- ⑤ Cassette clamp device
- ⑥ Operation panel
- ⑦ Air control box
- ⑧ Electrical control box
- ⑨ Power switch (also used as the emergency stop switch)
- ⑩ Thread stand
- ⑪ Bobbin winder device
- ⑫ Rotary knife device (subclass)

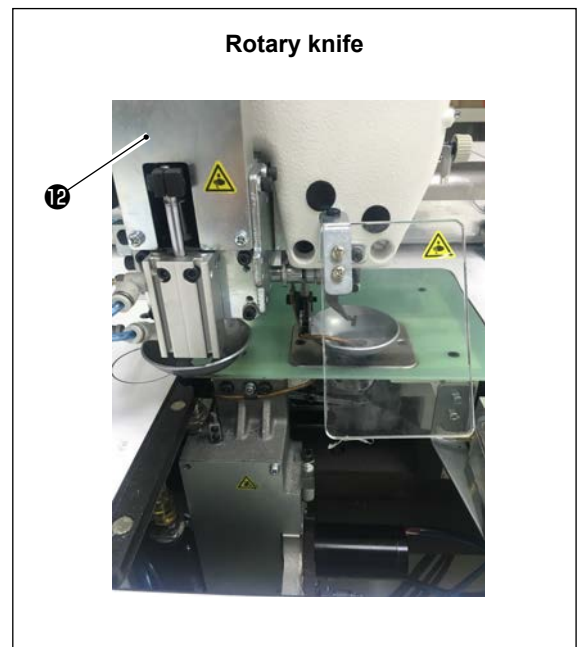

3. INSTALLATION

3-1. Setting up the sewing machine



3-1-1. Unpacking

1) Lift up clamp ❶ as shown in the picture.



If the clamp is not lifted up sufficiently, unpacking will not be smoothly carried out.

2) Firstly remove upper cover ❷. Then, remove the covers of the remaining four surfaces.



3) Detach the fixed metal plate of front and rear caster seats ❸ of the sewing machine.



4) Remove the plastic cover.



Cut the cable clip band to detach the sewing machine parts.



5) Remove the parts, accessory box and feed mechanism from the crate.

6) Move the sewing machine to the specified place with a folk lift. (Sewing machine weighs 640 kg)



7) Turn the casters to check to make sure that the sewing machine is levelled. Also make sure that the sewing machine is placed steadily with little wobbling. Turn red pad ④ to adjust the fixing pad.



* Necessary tools are contained in the accessory box.

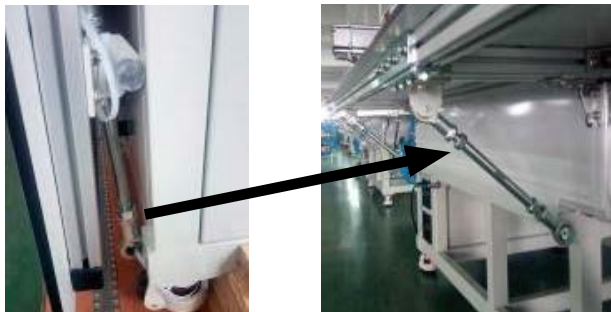
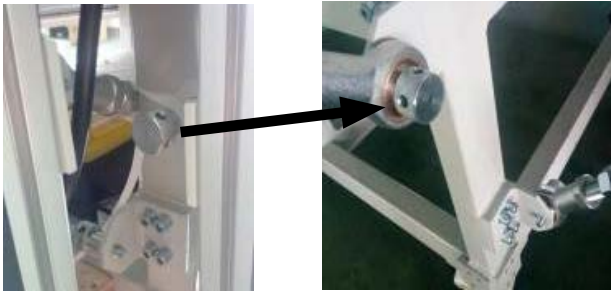
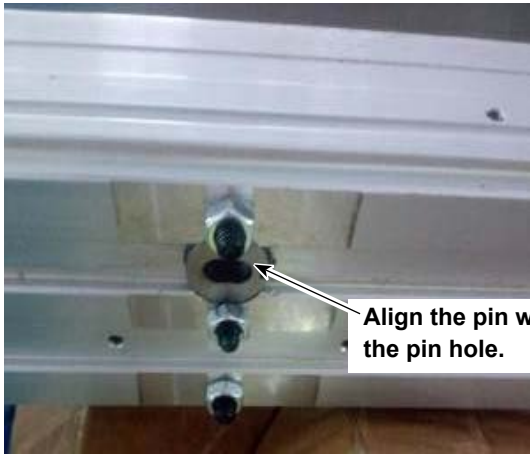
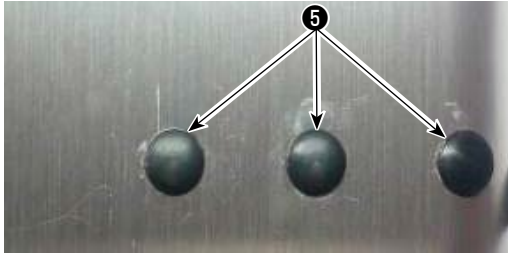
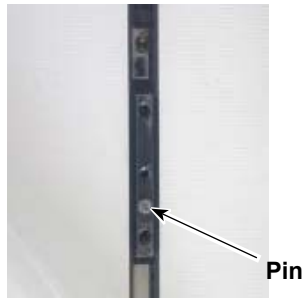

3-1-2. Setting up the X feed mechanism and the table

- 1) Detach the package.
- 2) Detach the fixing plate. Put the screw and nut you have detached in the accessory box.
- 3) Remove rubber plugs ⑤ . Tighten the screws that are placed under the rubber plugs with a wrench. Then, attach rubber plugs ⑤ .
- 4) Move the clamp to the center of the X feed mechanism before removing six nuts in order to prevent the clamp from interfering with screws when attaching them.
- 5) Take care not to allow the screws from slipping off the mounting holes after detaching the nuts. Put the nuts you have removed in the accessory box.

* Store the tools in the accessory box.

3-1-3. Setting up the table

- 1) Loosen the thumb screw as shown in Fig. I when setting up the left table, right table and front table (center).
- 2) Tighten the nuts and screws that are exclusive to the aluminum frame as shown in Figs. II and III when setting up the front table (left) and the front table (right).

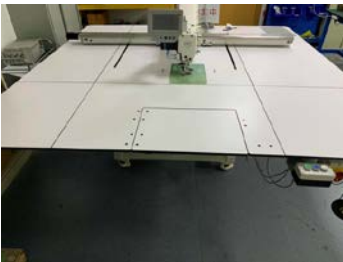

Fig. I



Fig. II



Fig. III





3-1-4. Setting up the switches, bobbin winder and switch button (asm.)

* Necessary tools are contained in the accessory box.

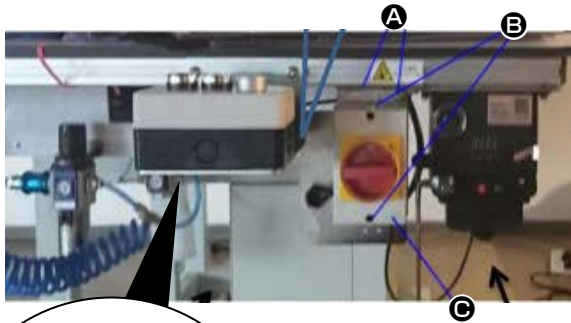

1) Secure the power switch plate to the aluminum frame of the front table (right) with two Phillips head screws **A**.

Secure power switch **C** to the plate with two Phillips head screws **B**.

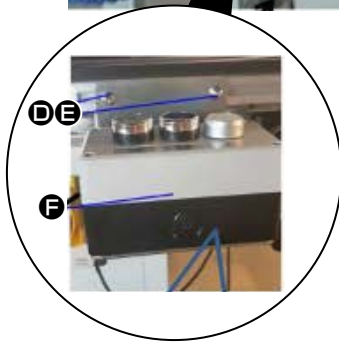

2) Secure switch button (asms.) **F** to the aluminum frame of the front table (right) with T screws **E** and nuts **D**.

Secure three switch buttons so that they point upward.

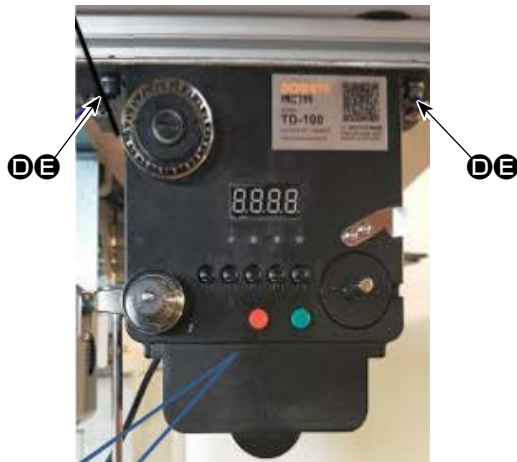

3) Secure the bobbin winder to the aluminum plate of the front table (right) with T screw **E** and nut **D**.



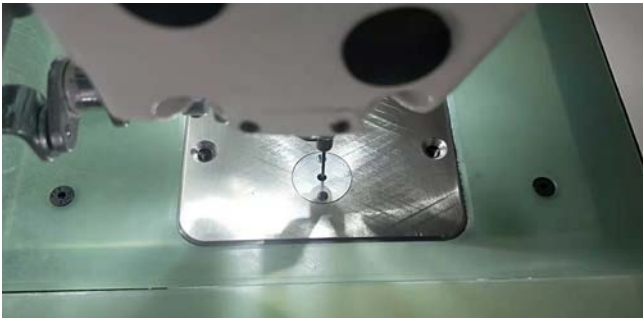

3-1-5. Check points and precautions before turning the power ON

- 1) Inspect the levelness of the sewing machine.
- 2) Inspect that the electric components and pneumatic components of the sewing machine have been securely assembled.
- 3) Inspect the alignment between the needle entry point and the center of needle hole in the throat plate of the sewing machine.
- 4) Detach the throat plate and inspect the relation between the needle and the hook.
- 5) Check the clearance provided between the X feed origin detection sensor and the detection plate.
- 6) Check that the X feed mechanism moves smoothly.

3-2. Installing the air hose



WARNING :

Check to be sure that the air hose is fully inserted into the air cock before supplying the air to the machine so as to prevent the air from being blown directly to the human body. Then, carefully open the air cock.



1) Connecting the air hose

Connect the air hose to ❶ .

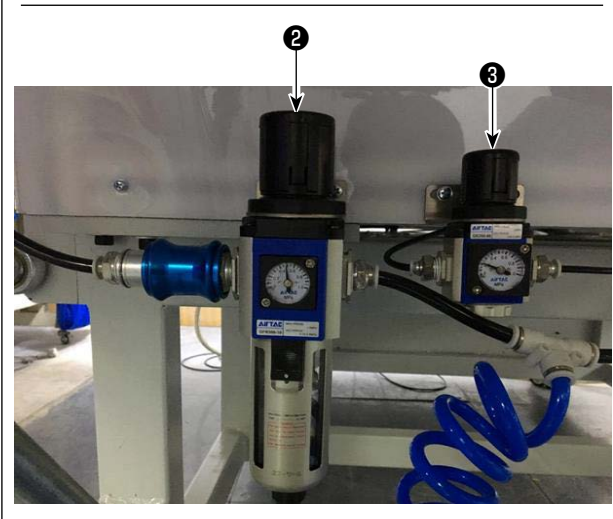

2) Adjustment of air pressure

Pull up air regulating knob ❷ . Then, turn it to adjust the air pressure to 0.5 - 0.55 MPa.

Then, push down air regulator knob ❷ .

Pull up air regulating knob ❸ . Then, turn it to adjust the air pressure to 0.15 MPa.

Then, push down air regulator knob ❸ .

❷ : Adjustment of the air pressure of the entire sewing machine

❸ : Adjustment of the air pressure of the disk presser

3-3. Cautions for the compressed air supply (source of supply air) facility

As large as 90 % of failures in pneumatic equipment (air cylinders, air solenoid valves) are caused by "contaminated air."

Compressed air contains lots of impurities such as moisture, dust, deteriorated oil and carbon particles. If such "contaminated air" is used without taking any measures, it can be a cause of troubles, inviting reduction in productivity due to mechanical failures and reduced availability.

Be sure to install the standard air supply facility shown below whenever the machine provided with pneumatic equipment is used.

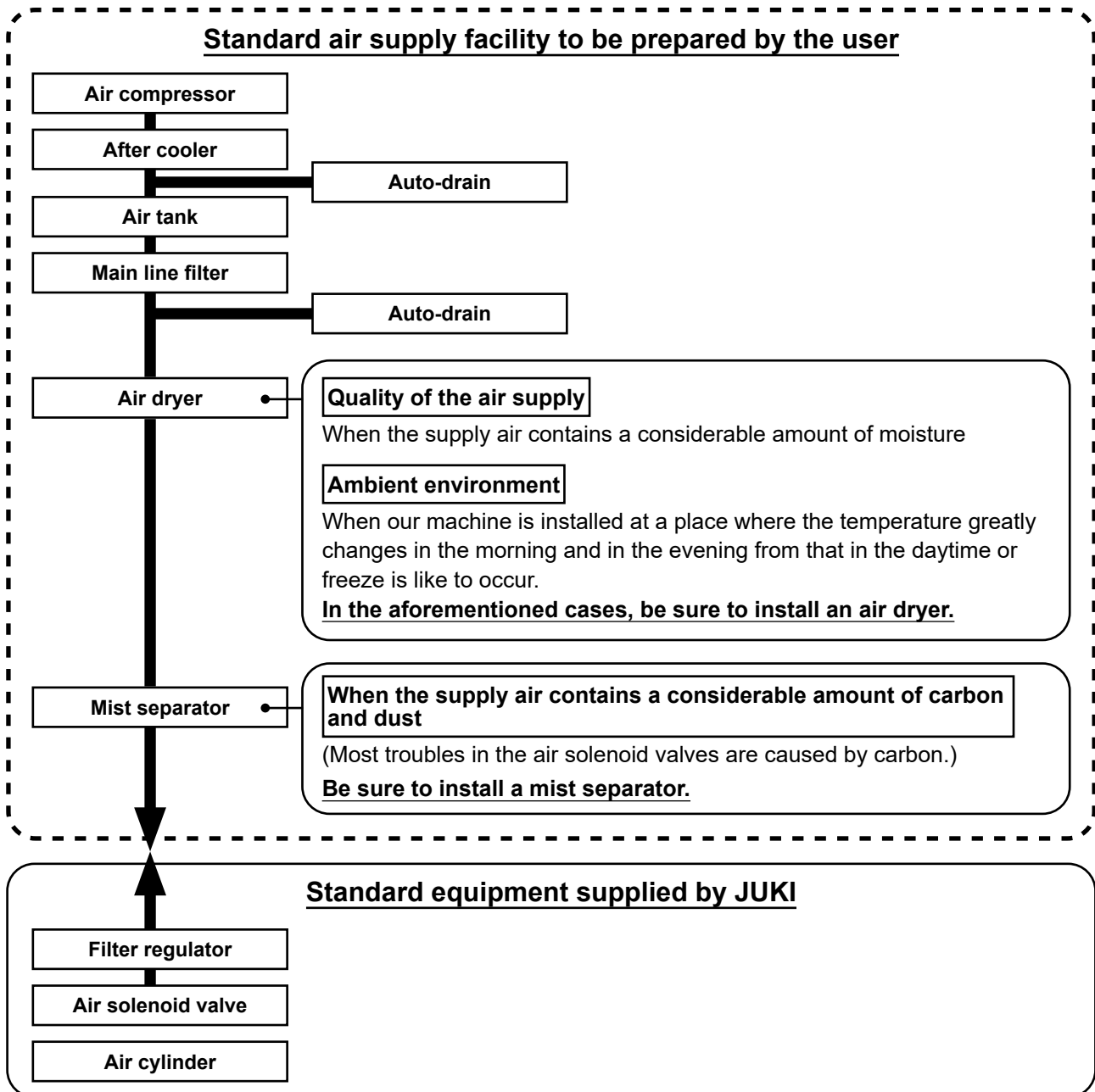

Cautions for main piping

- Be sure to slope main piping by a falling gradient of 1 cm per 1 m in the direction of air flow.
- If the main piping is branched off, the outlet port of the compressed air should be provided at the top part of the piping using a tee in order to prevent drain settling inside the piping from flowing out.
- Auto drains should be provided at all lower points or dead ends in order to prevent the drain from settling in those parts.



3-4. Installing the bobbin winder device

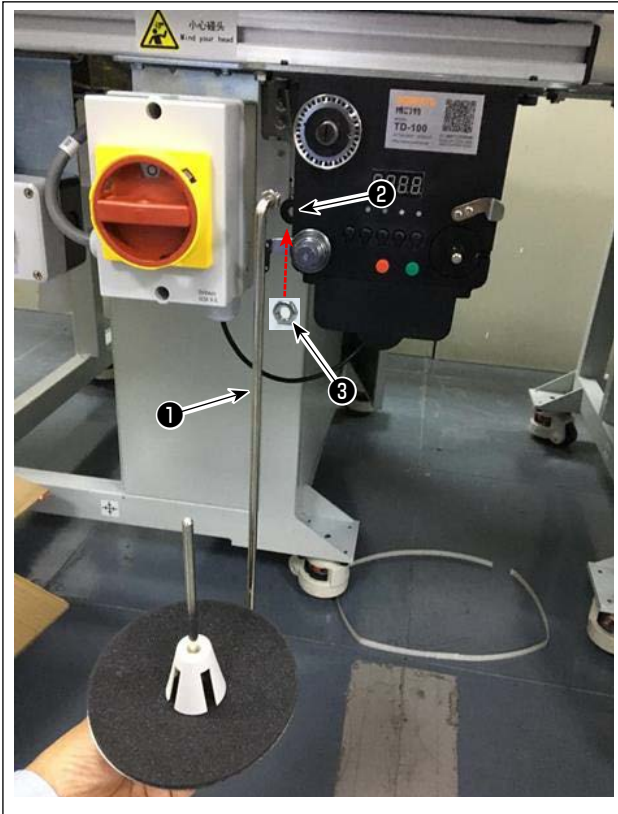

- 1) Insert bobbin winder disk mounting bar ① into hole ② in the bobbin winder and secure with nut ③.

3-5. Precautions for installation of the machine

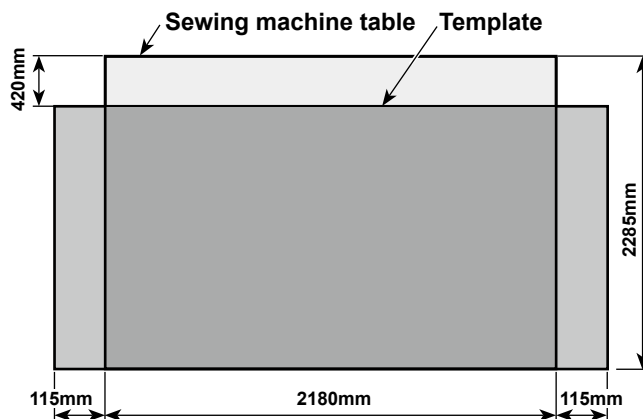
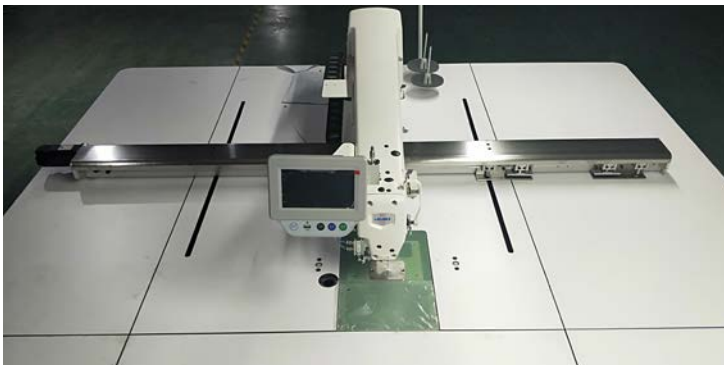

1. Depending on the size of template, the sewing machine may extend beyond the sewing machine table in X direction. Take care not to allow the machine to hit against someone standing near the table to cause injury.



2. Be sure to secure a space as wide as 500 mm or more around the sewing machine table (i.e., both in lateral and longitudinal directions).

4. PREPARATION OF THE SEWING MACHINE

4-1. Lubricating method and check of the oil quantity



WARNING :

Turn OFF the power before starting the work so as to prevent accidents caused by abrupt start of the sewing machine.

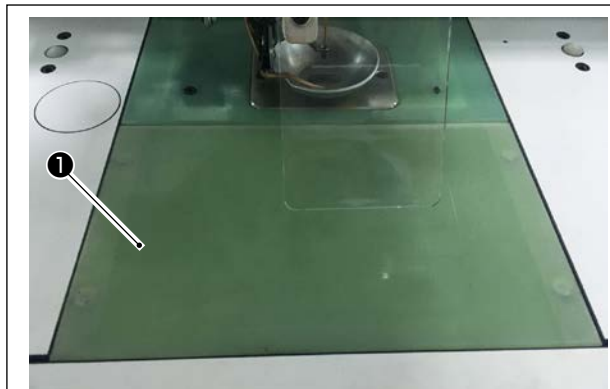

1) Detach cylinder lifting plate ❶ .

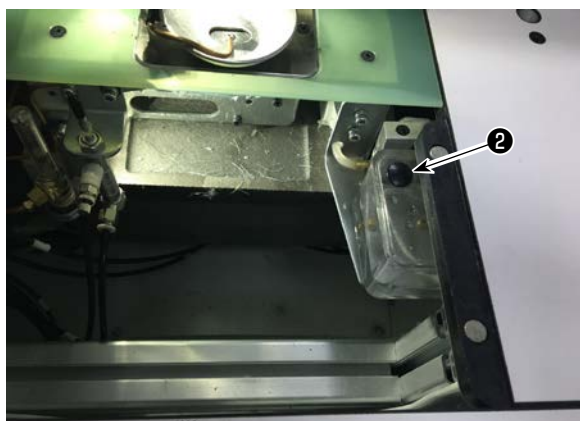

2) Remove rubber plug ❷ from the oil tank.



3) Fill the oil tank with the accessory oil (or the specified oil).

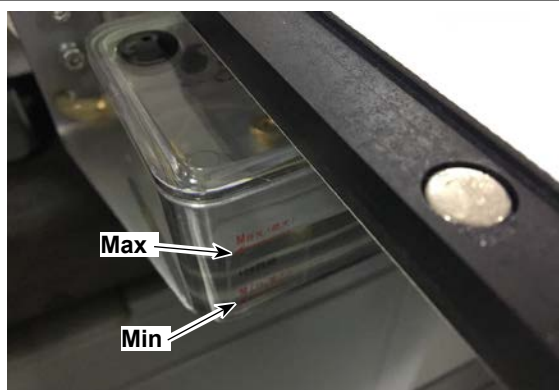

4) The adequate oil amount is obtained when the oil surface stays between the oil tank indications "Min" and "Max".

1. Do not use any oil other than the specified oil. After the completion of lubrication, securely attach the rubber plug and cylinder lifting plate to their original positions.



2. When you put the sewing machine into use for the first time after delivery or after having disused it for a long time, replenish the hook with a small amount of oil in advance.

4-2. Attaching the needle



WARNING :

Turn OFF the power before starting the work so as to prevent accidents caused by abrupt start of the sewing machine.

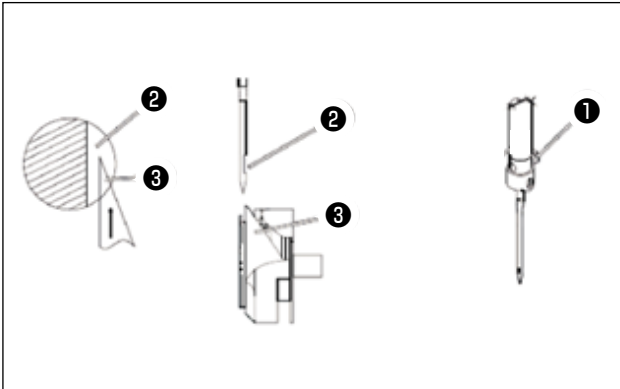

1) Loosen screw ❶ to remove the needle.



Be sure to hold the needle so that its groove ❷ faces toward blade point ❸ of the rotary hook.

2) Tighten screw ❶ .



In the case of replacing the needle with a needle which differs in specifications, be sure to re-adjust the distance from the rotary hook to the needle. If you neglect this re-adjustment, the problems listed below can occur.

1. Stitch skipping
2. Thread fray
3. Breakage of blade point of hook
4. Breakage of needle

4-3. Threading the machine head



WARNING :
Turn OFF the power before starting the work so as to prevent accidents caused by abrupt start of the sewing machine.

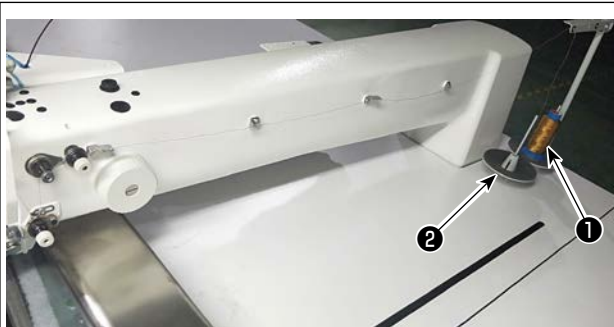

1) Put sewing machine thread ① on thread stand ②.



2) Pass the thread as illustrated in the figure.
Lastly, draw out thread end through needle eyelet by 50 to 60 mm.



4-4. Bobbin replacement procedure



WARNING :

Turn OFF the power before starting the work so as to prevent accidents caused by abrupt start of the sewing machine.

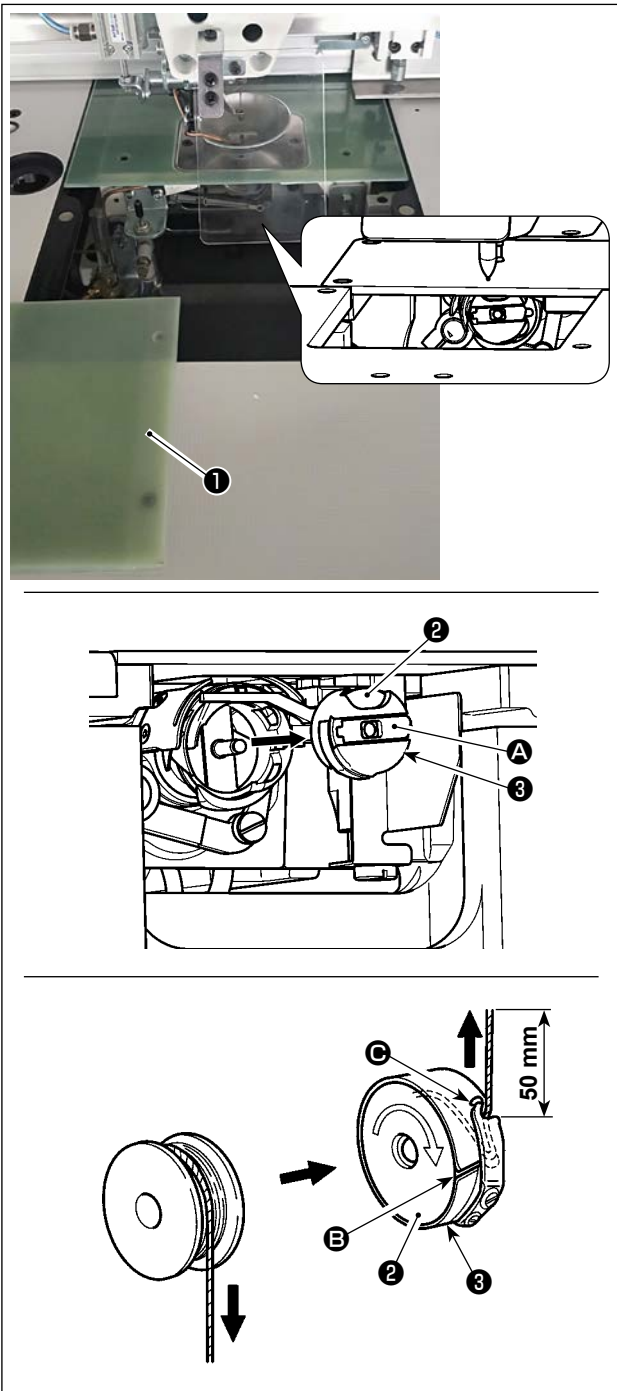

(1) Removing the bobbin case

- 1) Open cover ① . Then, the bobbin can be changed.
- 2) Raise latch A of bobbin case ③ , and remove the bobbin case ③ and the bobbin ② .



Check the position of your hands and the locations of goods before opening / closing cover ① so as to prevent the goods from being caught under the cover and to prevent bodily injury.
In addition, do not push cover ① with your hands placed on it.

(2) Installing the bobbin

- 1) Set the bobbin ② into bobbin case ③ in the direction shown in the figure.
- 2) Pass the thread through thread slit B of bobbin case ③ , and pull the thread as it is. By so doing, the thread will pass under the tension spring and be pulled out from thread hole C.
- 3) Pull out the thread by 50 mm from thread opening C.



If the bobbin ② is installed in the bobbin case orienting the reverse direction, the bobbin thread pulling out will result in an inconsistent state.

(3) Installing the bobbin case

- 1) Place the bobbin case in the hook with its knob A tilted and fully push it into the hook until you hear it click.
- 2) Close cover ① .



If it is not fully inserted, bobbin case ③ may slip off during sewing.

4-5. Adjusting the thread tension

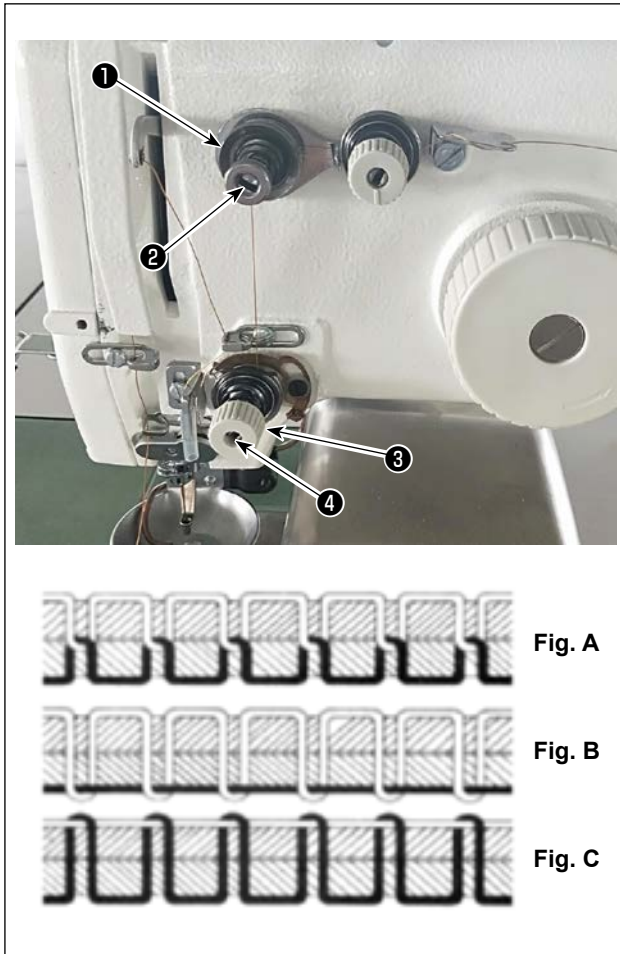

(1) Adjusting the needle thread tension

Thread tension controller No. 1 ①

When the tension disk of thread tension controller No. 2 ③ is loosened, such a small tension as to control the thread trimmer has to remain. The remaining tension is produced by tension controller ①. It is possible to determine the length of thread trailing from the needle after automatic thread trimming by adjusting nut ② of the thread tension controller. The length of thread trailing from the needle is reduced by turning nut ② clockwise (+). It is increased by turning nut ② counterclockwise (-).

Thread tension controller No. 2 ③

The tension (applied to the thread coming from the needle) controlled with thread tension controller No. 2 ③ should be set as low as possible so that the needle thread and bobbin thread are interlaced together at the center of material thickness (Fig. A). If the thread tension is excessively high when sewing a light-weight material, the material may become wrinkled or thread may break. The tension applied to the thread coming from the needle is increased by turning nut ④ clockwise (+). It is decreased by turning nut ④ counterclockwise (-).

Fig. A: Threads are interlaced together accurately at the center of material thickness.

Fig. B: Needle thread tension is too low or bobbin thread tension is too high.

Fig. C: Needle thread tension is too high or bobbin thread tension is too low.

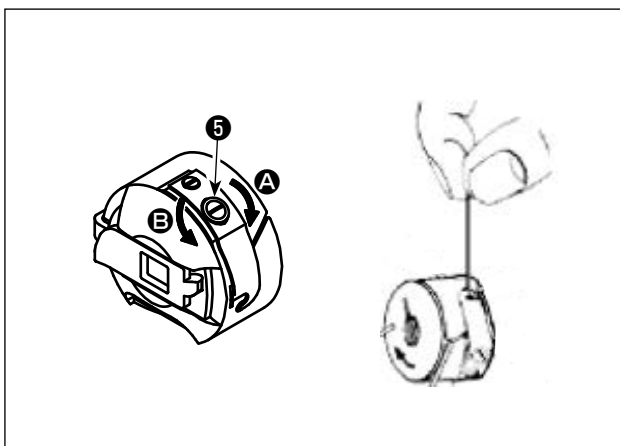

(2) Adjusting the bobbin thread tension

- 1) Turn tension adjusting screw ⑤ clockwise (in direction A) to increase or counterclockwise (in direction B) to reduce the bobbin thread tension. Recommended value: Approximately 25 g
The bobbin case will come down slowly by its dead weight by holding it as illustrated in the figure.

4-6. Adjusting the thread take-up spring and the thread breakage detector plate

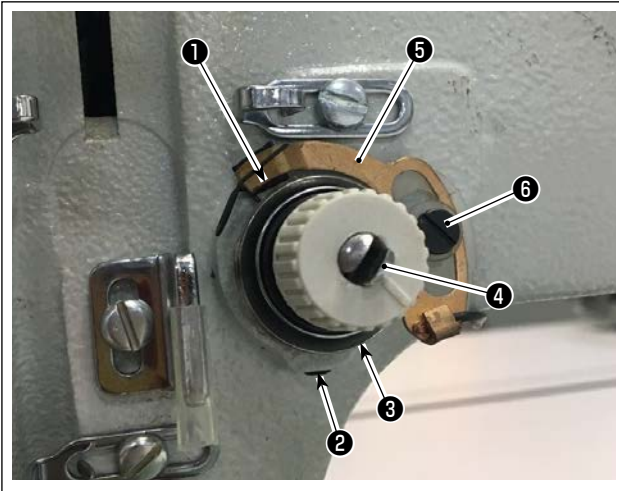

- 1) Adjusting the stroke
Loosen setscrew ② . Turn thread tension controller ③ . Turning it clockwise will increase the stroke of the thread take-up spring ① and the thread drawing amount will increase.
- 2) Adjusting the pressure
To change the pressure of the thread take-up spring ① , insert a thin screwdriver into the slot of thread tension post ④ while screw ② is tightened, and turn it. Turning it clockwise will increase the pressure of the thread take-up spring ① . Turning it counterclockwise will decrease the pressure.
- 3) Adjusting the thread breakage detector plate
Loosen setscrew ⑥ . Adjust the position of thread breakage detection plate ⑤ so that the contact depth between thread breakage detection plate ⑤ and thread take-up spring ① becomes 0 to 0.2 mm.



Adjust so that thread breakage detector plate ① does not touch any adjacent metallic parts other than thread take-up spring ② . If the thread breakage detection plate comes in contact with any other metal part, a maloperation can occur.

4-7. Adjusting the thread take-up stroke

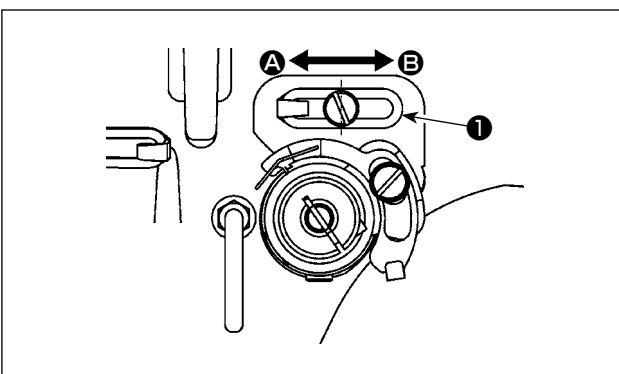

- 1) When sewing heavy-weight materials, move thread guide ① to the left (in direction ①) to increase the length of thread pulled out by the thread take-up.
- 2) When sewing light-weight materials, move thread guide ① to the right (in direction ②) to decrease the length of thread pulled out by the thread take-up.
- 3) Normally, thread guide ① is positioned in a way that the center of elongated hole is aligned with the center of the screw.

4-8. Needle-to-hook relationship



WARNING :

Turn OFF the power before starting the work so as to prevent accidents caused by abrupt start of the sewing machine.

(1) Needle and hook, and angle setting

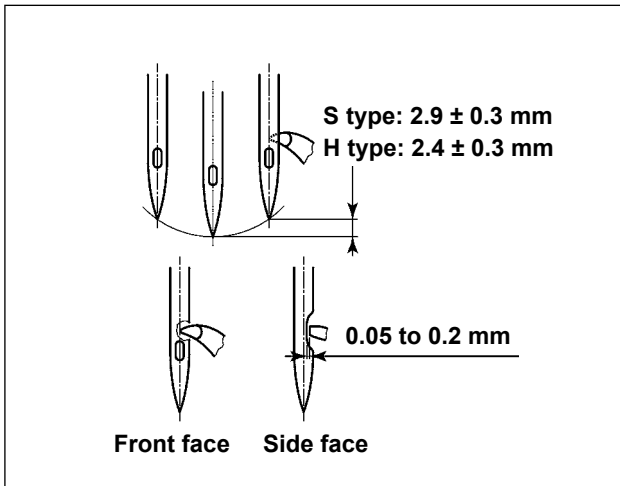

- 1) For the S type, the relation between the needle bar height and the hook position should be adjusted when the needle bar goes up from its lower dead point by 2.9 ± 0.3 mm. For the H type, it should be adjusted when the needle bar goes up from its lower dead point by 2.4 ± 0.3 mm.
- 2) When observing from the front face of the sewing machine, the blade point of hook seems to overlap with the center of needle.
- 3) When observing from the side face of the sewing machine, the clearance provided between the blade point of hook and the scarf of needle is 0.05 to 0.2 mm.



Caution
If thread breakage occurs, the thread can be tangled in the hook. In such a case, remove the thread being tangled in the hook carefully. Then, re-start sewing.

- 4) As shown in the figure, the electrical shaft angle setting QEP value displayed on the operation panel becomes 570 to 575.

(2) Position of the needle and the inner hook holder

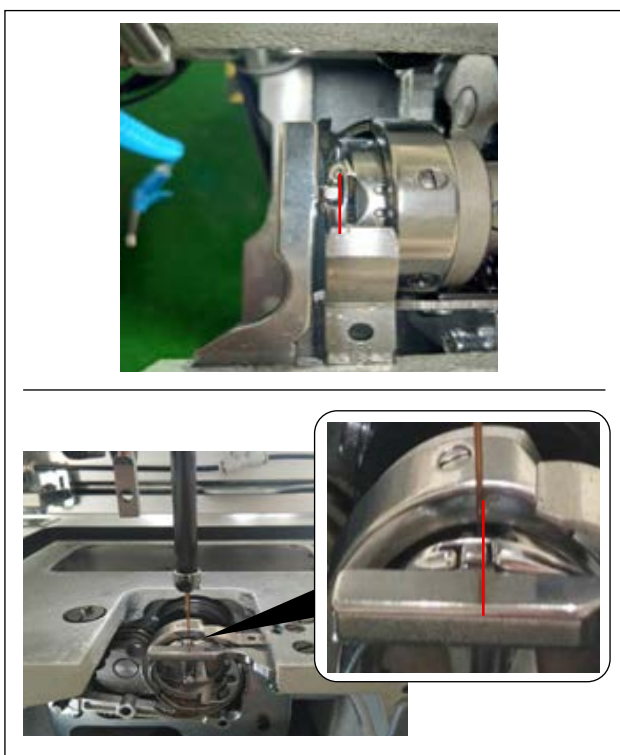

Longitudinal position of the inner hook holder and needle: The front end of needle is aligned with the inner hook.

Lateral position of the inner hook holder and needle: The rightmost end of projection of inner hook holder is aligned with the right side of needle.

(3) Adjusting the hook timing

The timing gauge is supplied for the machine as an accessory.

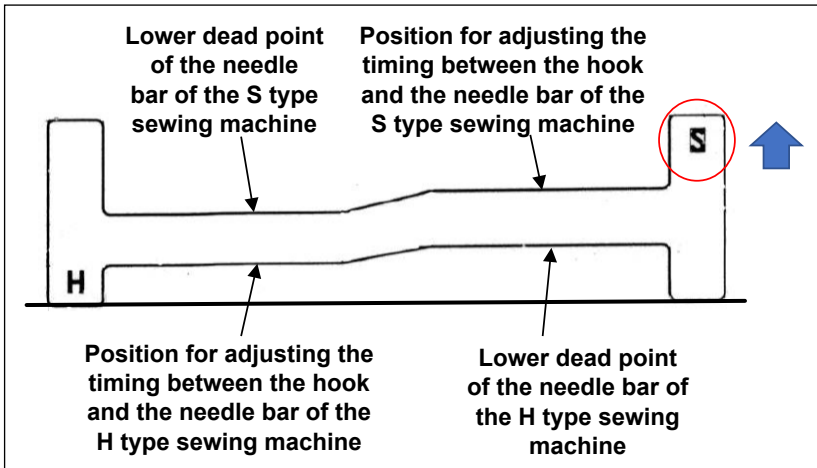

Adjust the hook timing according to the sewing type (S type / H type) of the sewing machine.

Turn the timing gauge upside down according to the sewing machine type as shown in the figure on the left.

For the S type :

Position the timing gauge with its S inscription turned up

For the H type :

Position the timing gauge with its H inscription turned up



Loosen needle bar connection setscrew. Adjust the height of the needle bar.

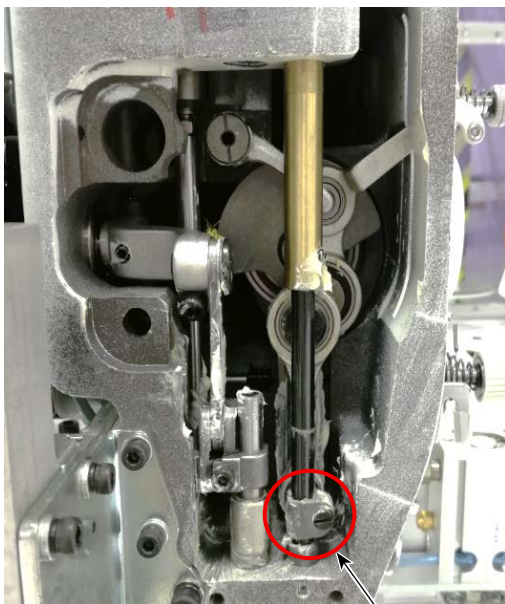

Needle bar connection setscrew

- 1) Put the timing gauge on the resin cover. Then, adjust the lower dead point of the needle bar first.
- 2) Then, turn the timing gauge by 180 degrees of an angle longitudinally. Adjust the hook timing position.

When adjusting the hook timing, it is necessary to put the jig on the left side of the needle to prevent the jig from coming in contact with the needle bar thread guide.



Align the timing gauge with the end surface of the needle bar.

4-9. How to wind a bobbin

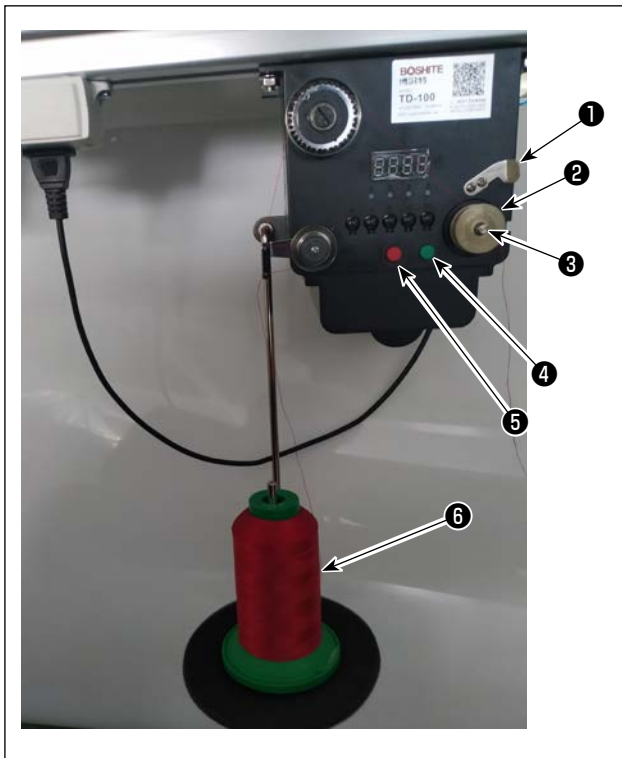

- 1) Put bobbin ② on bobbin winder shaft ③ .
- 2) Pass sewing thread ⑥ through spool rest rod.
- 3) Pass the thread as illustrated in the figure.
- 4) Manually wind thread on bobbin ② by several turns clockwise.
- 5) Press button ④ to start winding thread on the bobbin.
- 6) When the bobbin thread amount wound on the bobbin reaches the set amount (80 %), the bobbin winder automatically stops turning. Or, press button ⑤ to stop the bobbin winder.
- 7) Trim the thread with thread trimmer ① . Detach bobbin ② .

4-10. Adjusting the needle bar height



WARNING :

Turn OFF the power before starting the work so as to prevent accidents caused by abrupt start of the sewing machine.

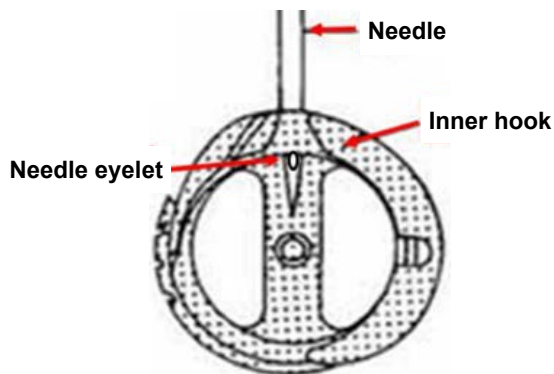
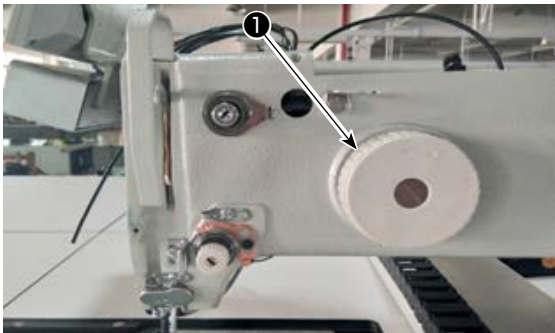

H type



Turn pulley ❶ counterclockwise to lower the needle bar to its lower dead point.

At this time, the needle bar connecting rod and the needle bar are located on the straight line as illustrated in the figure.

S type

Expose a half of the needle eyelet from the inner hook (standard position).

Determine the needle bar height according to the material to be used.

1. Since woven fabric in general consists of two or three layers of material, expose a half of the needle eyelet from the inner hook.
2. For the resilient materials such as knit or comparatively heavy-weight materials, expose two-thirds of needle eyelet from the inner hook.
3. The appropriate needle bar height varies depending on the type and/or thickness of material.



H type

Adjust the distance from the flat portion of needle bar to the throat plate to 18.4 ± 0.3 mm. Expose two-thirds of the needle eyelet from the inner hook.

4-11. Adjusting the position of the thread trimmer



WARNING :

Turn OFF the power before starting the work so as to prevent accidents caused by abrupt start of the sewing machine.

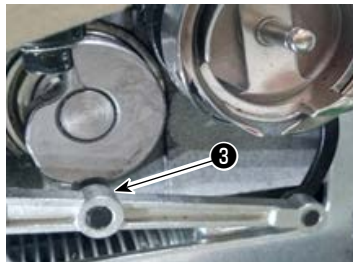
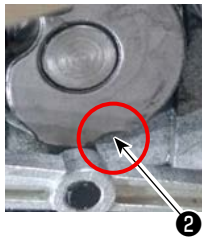
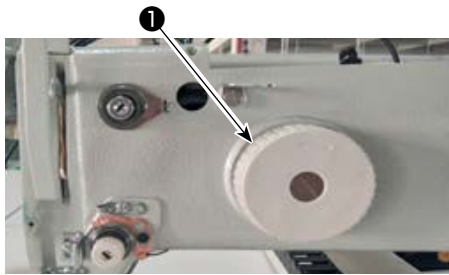

(1) Adjusting the position of the thread trimming cam

- 1) Turn pulley ① to engage needle bearing ③ of the thread trimmer connecting rod with groove ② in the thread trimming cam.

The specified QEP value of the electrical shaft angle setting parameter has been factory-adjusted to 290 at the time of shipment. Finely adjust the parameter according to the difference in material.

The moving knife is in parallel with the moving knife base

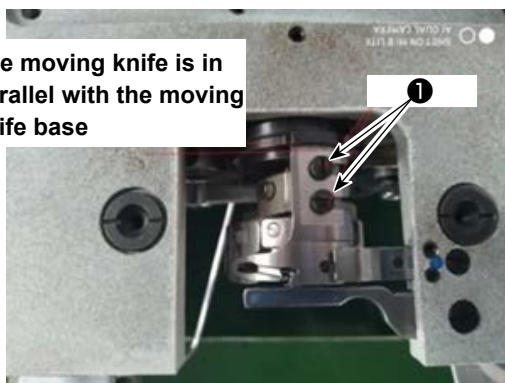

(2) Adjusting the position of the moving knife and counter knife

- 1) Attach the moving knife to the moving knife base. Push the moving knife to the right to make the tail of the moving knife in parallel with the moving knife base. At this time, the blade point of moving knife is aligned with the needle. Tighten moving knife clamping screw ① .

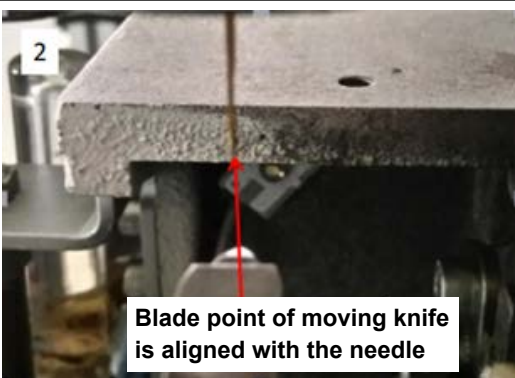

Blade point of moving knife is aligned with the needle



Blade point of moving knife



2) Attaching the counter knife

The tail portion of the counter knife has a hole. Inserting 2.5 hexagonal wrench key ② into that hole, tighten the fixation screw of the counter knife while aligning the tail portion of the counter knife with the hexagonal wrench key.

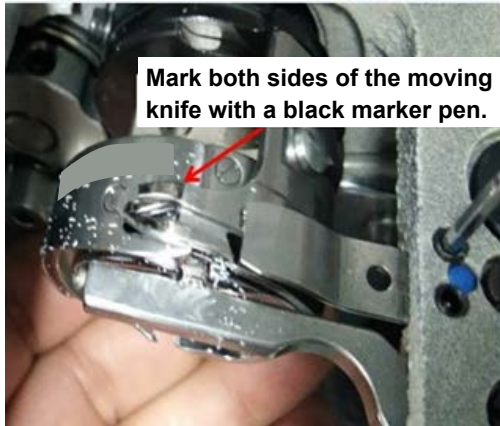

3) Mark the 5 mm position of the moving knife blade with a black marker pen. Adjust the counter knife pressure with counter knife pressure adjustment screw ③ .

After you have completed adjustment, push down the moving knife to re-adjust the moving knife pressure in repetition until both sides, with black markers, of the moving knife are simultaneously rubbed by the counter knife without fail. In addition, the friction force between the moving knife and the counter knife can be minimized by trimming three used machine-sewing threads.

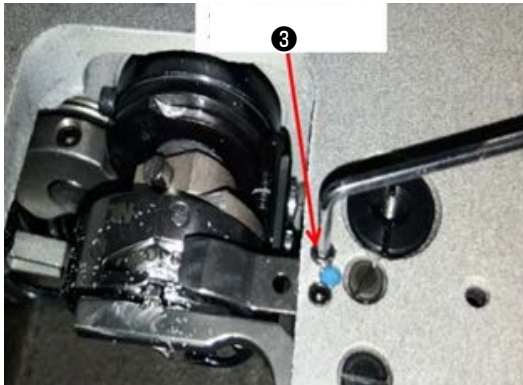

4-12. How to attach / remove the cylinder lifting plate

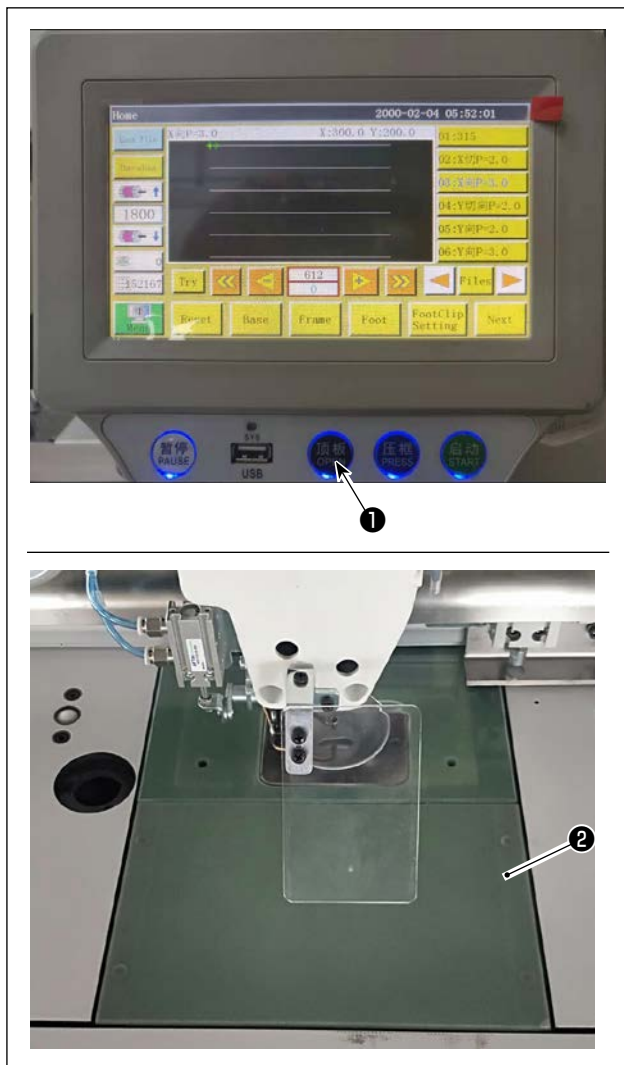

1) While the power to the sewing machine is turned ON, press switch ① .

2) Cylinder lifting plate ② comes off upward. Remove it. (The cylinder pushes up the lifting plate.)

3) To install cylinder lifting plate ② , press switch ① . (The cylinder comes down to allow the cylinder lifting plate to be installed. The lifting plate is then secured with a magnet.)

4-13. How to confirm the amount of oil (oil splashes) in the hook



WARNING :

Be extremely careful about the operation of the machine since the amount of oil has to be checked by turning the hook at a high speed.

(1) How to confirm the amount of oil (oil splashes)

① Amount of oil (oil splashes) confirmation paper

* Use any paper available regardless of the material.

② Position to confirm the amount of oil (oil splashes)

Oil splashes confirmation paper



When carrying out the procedure described below, confirm the state that the needle thread from the thread take-up lever to the needle and the bobbin thread are removed, the presser foot is lifted and the slide plate is removed. At this time, take extreme caution not to allow your fingers to come in contact with the hook.

- 1) Check to make sure that the oil quantity is adequate referring to "[4-1. Lubricating method and check of the oil quantity](#)" p. 12.
- 2) If the machine has not been sufficiently warmed up for operation, make the machine run idle for approximately fifteen minutes.
- 3) Place the amount of oil (oil splashes) confirmation paper under the hook while the sewing machine is in operation.
- 4) Confirmation of the amount of oil (oil splashes) should be completed in ten seconds.

(2) Sample showing the appropriate amount of oil (oil splashes)

Appropriate amount of oil (smaller)

Splashes of oil from the hook

Appropriate amount of oil (larger)

Splashes of oil from the hook

Min. 0.5 mm

- 1) The state given in the figure above shows the appropriate amount of oil (oil splashes).
- 2) Check the oil amount (oil splashes) three times (on the three sheets of paper), and adjust so that it should not change.



Do not excessively increase/decrease the amount of oil in the hook. If the amount of oil is too small, the hook will be seized (the hook will be hot). If the amount of oil is too much, the sewing product may be stained with oil.

4-14. Adjusting the amount of oil in the hook



WARNING :

Turn OFF the power before starting the work so as to prevent accidents caused by abrupt start of the sewing machine.

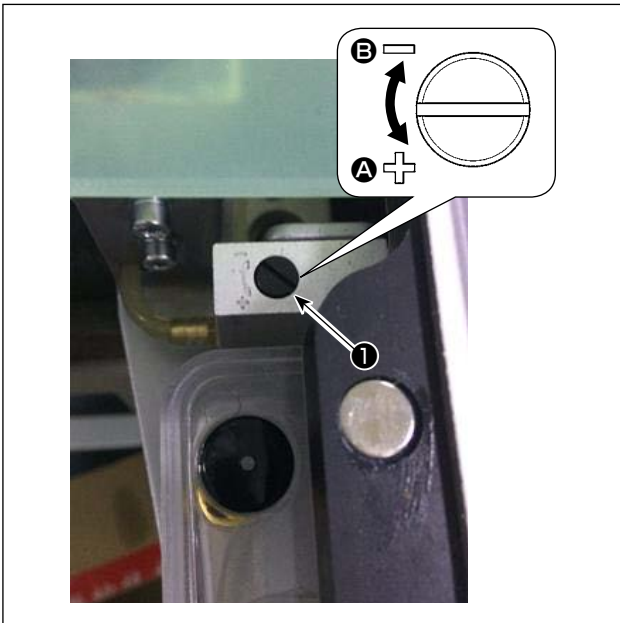

- 1) Remove the cylinder lifting plate.
- 2) The oil amount is increased by turning screw ① in the direction of arrow ➊, or decreased by turning it in the direction of arrow ➋.
- 3) After the completion of adjustment, attach the cylinder lifting plate.



1. After the adjustment, check the oil quantity by running the sewing machine idle for approximately 30 seconds, as well as by checking it in comparison with the sample showing the adequate oil quantity. (Refer to "4-13. How to confirm the amount of oil (oil splashes) in the hook" p. 25.)
2. In the case of adjusting the hook oil quantity, firstly adjust the oil quantity by turning oil quantity adjustment screw in the direction of arrow ➊ to increase it. Then, adjust the hook oil quantity by turning the adjustment screw in the direction of arrow ➋ to decrease it.
3. The hook oil quantity has been factory-adjusted at the time of shipment, based on the maximum sewing speed of sewing machine. When the customer always operate the sewing machine at a low speed, the hook oil quantity may run short causing a sewing machine failure. To prevent such a failure, adjustment of the hook oil quantity is required when the customer runs the sewing machine at a low speed at all times.

4-15. Adjusting the needle hole in the throat plate and the needle



WARNING :

Turn OFF the power before starting the work so as to prevent accidents caused by abrupt start of the sewing machine.

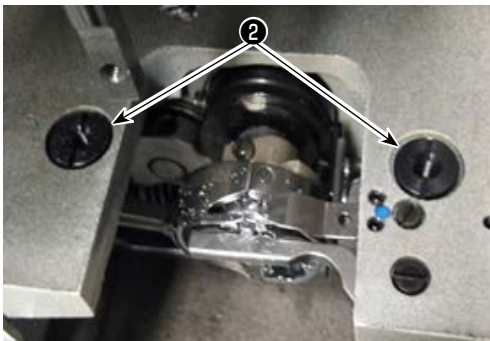

In the case the needle does not come down to the center of needle hole in the throat plate, the position of the throat plate can be adjusted with screw ❶ .

- 1) Attach the throat plate.
- 2) Loosen two needle hole adjustment eccentric screws ❷ of the throat plate. Adjust the position of the throat plate so that the needle is aligned with the center of needle hole in the throat plate by moving the throat plate.
- 3) Tighten needle hole adjustment eccentric screws ❷ of the throat plate.

4-16. Setting the mechanical origin



1

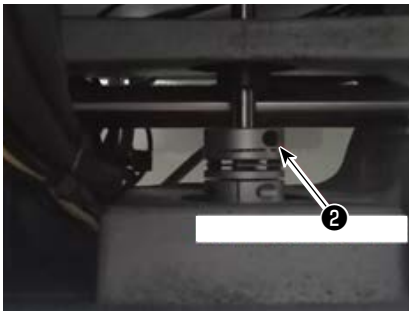

2



3

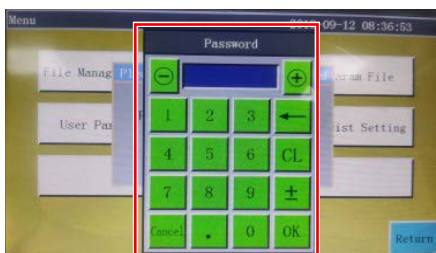
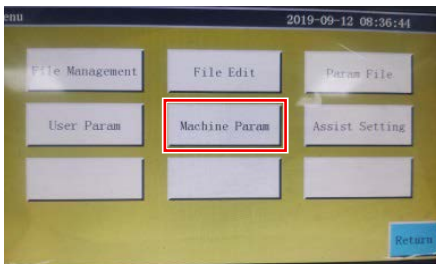

4



- 1) Slightly tighten screw ② on the lower shaft side. Then, turn the pulley to position screw ① on the main shaft motor so that it is levelled and faces upward.
- 2) Holding the pulley, press  ③ on the main screen of the electrical box.
- 3) When you press the "Machine setting parameter", ④ is displayed. When you enter password "11111111", screen ⑤ is displayed.
- 4) On the screen that is displayed by pressing the "Axial angle setting", set the QEP value to 245, tighten screw ① on the main shaft motor side, and loosen screw ② on the lower shaft side. Then, turn the pulley to bring the needle bar to its upper dead point.
- 5) Holding the pulley (not to allow the needle bar to move), click the "QEP value" of the "Axial setting parameter" on the screen. Adjust the QEP value to 0 (zero). Then, tighten screw ② on the lower shaft side.
- 6) At this point, the origin adjustment has been completed. Now, turn the pulley again to check that the QEP value of the needle bar at its upper dead point is 0 (zero). As long as the aforementioned QEP value is 0 (zero), the mechanical origin has been adjusted properly.

5

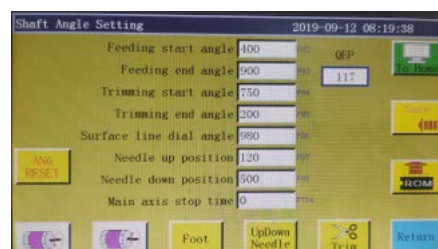
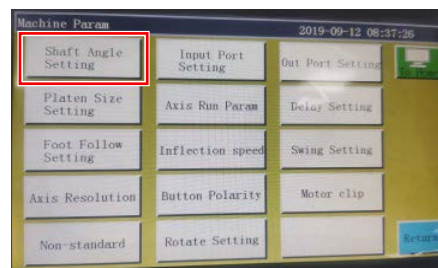

4-17. Adjusting the disk presser pressure

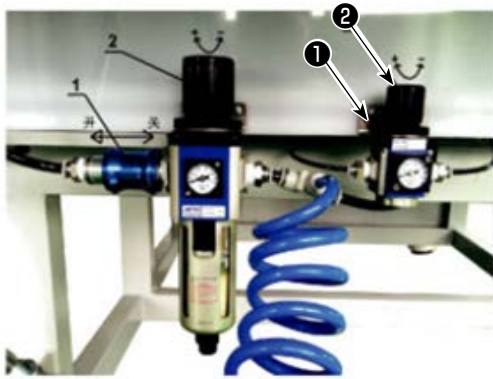

1) Adjust the disk presser air cylinder pressure regulation valve **1** . Pull up nut **2** . Then, turn the nut clockwise to increase the disk presser pressure or turn it counterclockwise to decrease it. The air pressure has been factory-set to 0.15 MPa at the time of shipment. Adjust it appropriately while checking the actual sewing state.



2) Adjust the lifting speed of disk presser air cylinder by adjusting cylinder speed control valve **3** that is located outside the disk presser air cylinder.

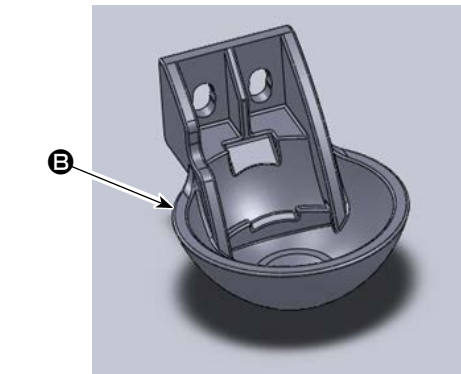

3) Changing the disk presser

Check the actual sewing operation. Use the disk presser or the plastic disk presser according to the condition of actual sewing operation.

A Disk presser (factory-attached at the time of shipment)

B Plastic disk presser

When changing the disk presser with the plastic disk presser or vice versa, try to position the disk presser so that its bottom surface is in parallel with the hook cover. Adjust the height of the disk presser according to the actual material thickness (i.e., height) while taking care not to allow the disk pressers to come in contact with the intermediate presser.

4-18. Adjusting the thread end position at the beginning of sewing

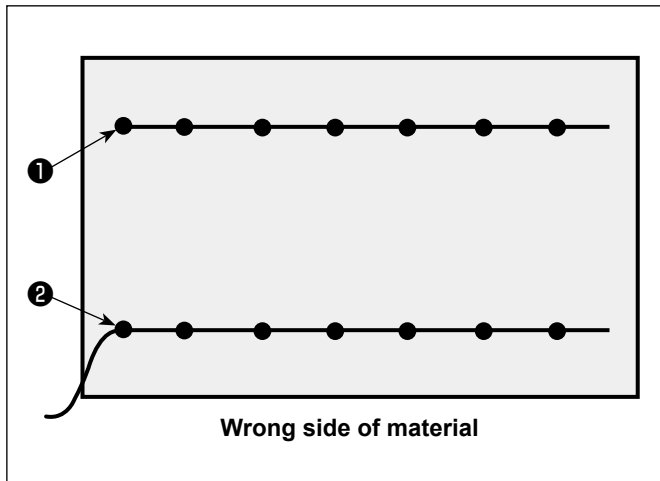

It is possible to set the needle thread end position at the beginning of sewing to top side ① or underside ② of material.

The condition of the needle thread end is changed over between the aforementioned two settings by actuating the function for pulling the thread by the wiper and for holding the thread by upward air blow.

① To put the needle thread end on the top of material

The function for pulling the thread by the wiper and for holding the thread by blowing air upward is actuated.

② To put the needle thread end on the underside of material

The function for pulling the thread by the wiper and for holding the thread by blowing air upward is de-actuated.

4-19. Adjusting the electronic intermediate presser stroke

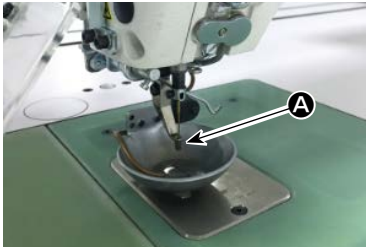

It is necessary to adjust the intermediate presser stroke (A) appropriately since there would be the need for preventing stitch skipping depending on thickness or type of the material.

- 1) Press  ① on the main screen of electrical box.
- 2) When you press the "Machine setting parameter", ② is displayed.
When you enter the password "11111111", screen ③ is displayed.
- 3) On the screen that is displayed by pressing the "Presser follow-up setting", set the parameter (the follow-up height of presser foot has been factory-adjusted to 2 mm at the time of shipment).

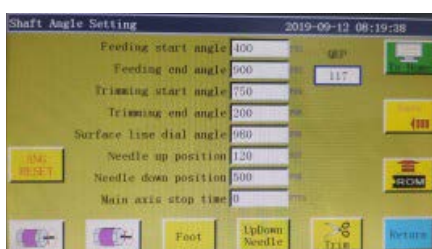
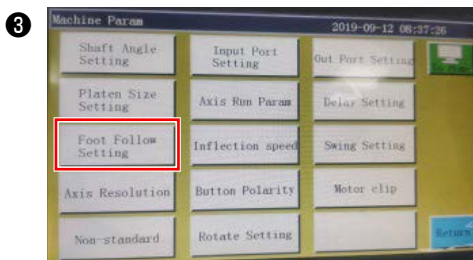
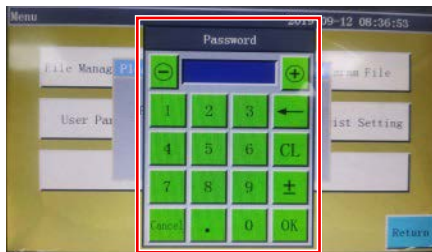
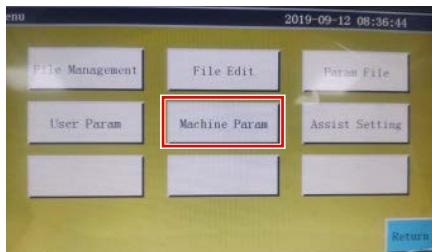
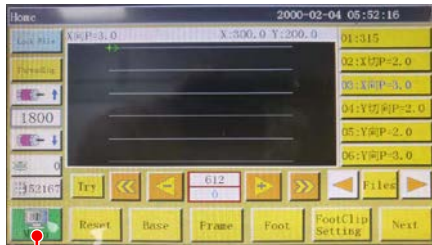

4-20. Adjusting the needle thread air blower



Blow-up pipe ❶ blows air to blow up the thread end trailing from the needle to bring it under disk presser ❷ at the beginning of sewing by controlling the solenoid valve of the electrical system.

Thread end is pushed by air between the disk presser and the pattern at the beginning of sewing. In the case the thread end cannot be pushed due to the location and direction of slits on the pattern, adjust the blowing direction of the air to allow the thread end to be pushed by air.

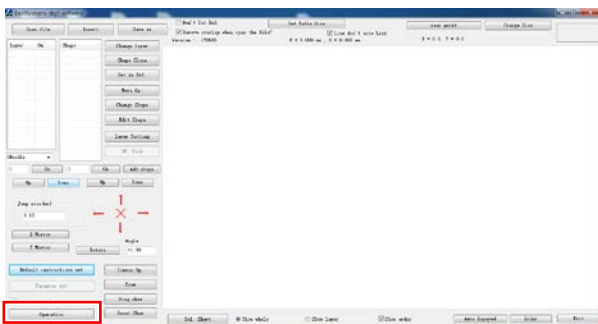

Launch the pattern creation software to operate and process the pattern to be sewn.

On the screen that is displayed by clicking "Operation processing" ❸, click ❹ ("Enter I/O") and change the "I/O" to 5.

Change the "Level" to "high" ("low" refers to "turning OFF"). Click ❺ ("Delay"). Change the "Delay (msec)" to 225.

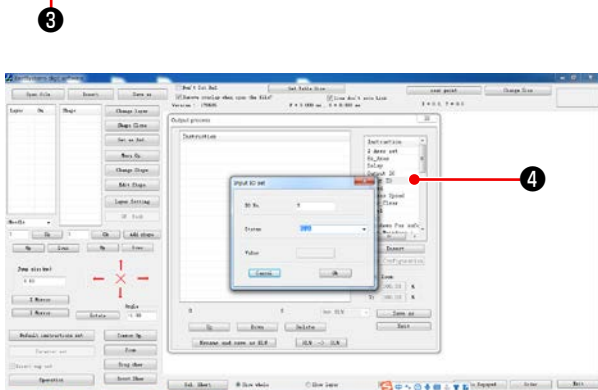

The needle thread air blower and the wiper cannot be used simultaneously.

1. The wiper provides the function for bringing the needle thread above the presser foot.

2. The needle thread air blower provides the function for bringing the needle thread under the disk presser.

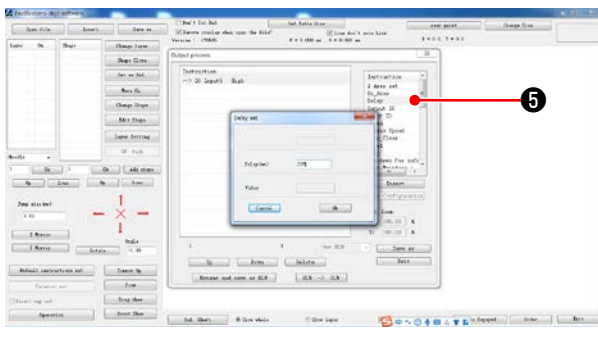

4-21. Making a template

(1) Machining a template

12080 type template of dimensions of the maximum sewing range

- Material of template: PVC plate
- Template thickness: 1.5 mm thick PVC plate
- Adjust the template size according to the cloths and/or pattern to be sewn. The size must not exceed the maximum dimensions of the relevant specifications.
- Check complexity of the pattern to be sewn. Then, select the sewing slits from the range of 6 mm to 8 mm according to the complexity of the pattern.
- Locus of sewing slits on the template should be designed according to the pattern to be sewn or intended machining.
- Select the suitable pattern carving machine. The template must be machined by the qualified engineers who have successfully finished the on-the-job training.
- After the completion of machining upper and lower templates, deburr the templates and the top surface of the template mounting plate.

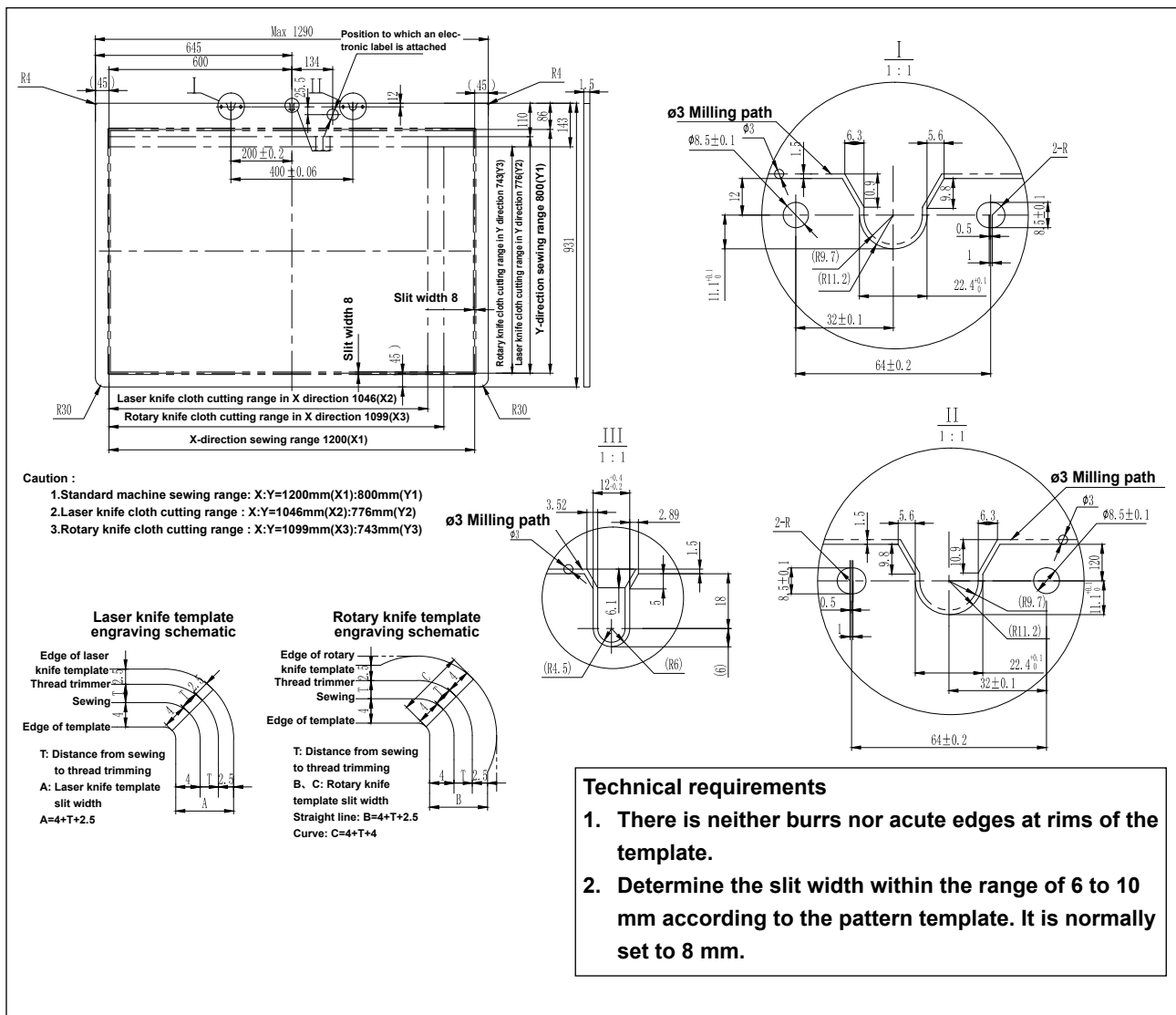

(2) Attaching the templates

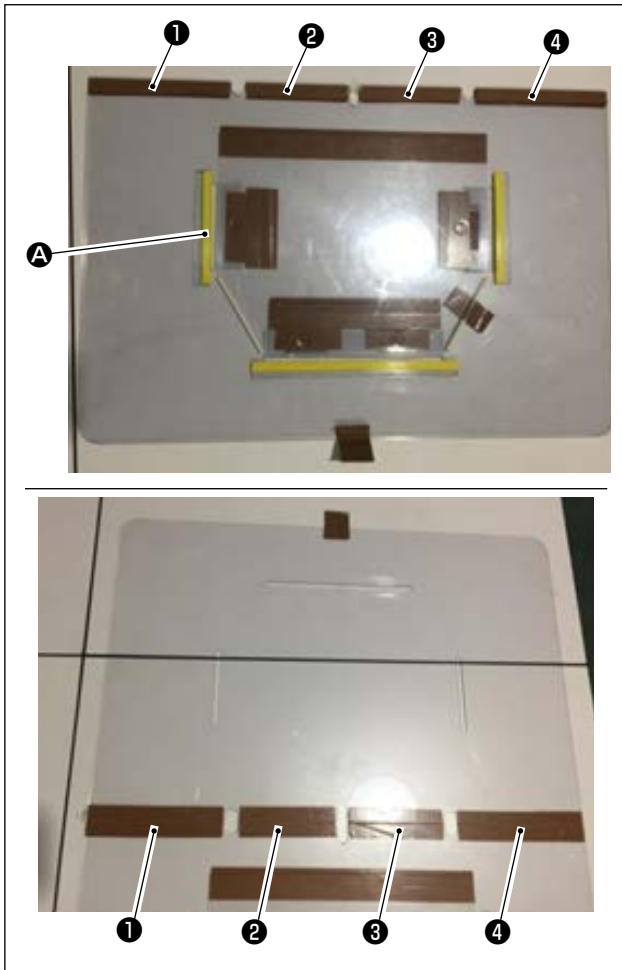

Machine the upper and lower templates based on the design.

- 1) Put the upper template on the lower template, as shown in the figure, and adjust so that sewing slits **A** on the upper and lower templates are aligned. Affix exclusive template tape (36 mm wide) to portions **1** , **2** , **3** and **4** as illustrated in the figure.
- 2) To produce more beautiful seams, it is recommended to firmly secure the material at the correct position by affixing sand tape, double-sided adhesive tape, etc. on the slits of the upper and lower templates or put positioning pins at appropriate locations in order to prevent the material slippage.

4-22. Preparation for sewing



- 1) Turning ON the main power switch.
Press button **1** to turn ON the main power switch.
- 2) Turning ON the main air source switch
Move main air valve **2** to the right to open the main air source.

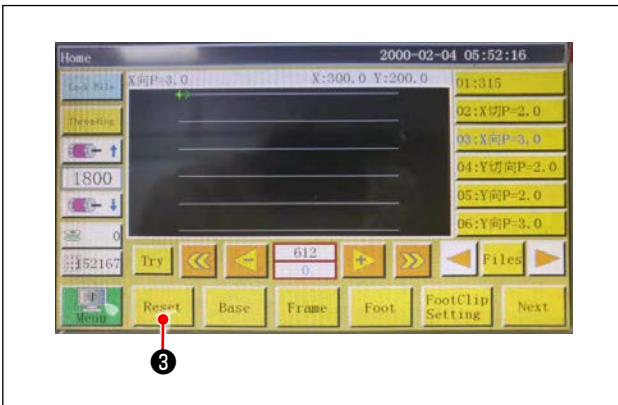

- 3) Resetting the equipment
When the equipment is reset by pressing  **3**, the needle stops at its upper stop position, and the disk presser and intermediate presser go up.
- 4) Read the pattern data to be sewn, or directly edit the pattern data on the operation panel.
Refer to the Instruction Manual for the computer-control system for details.

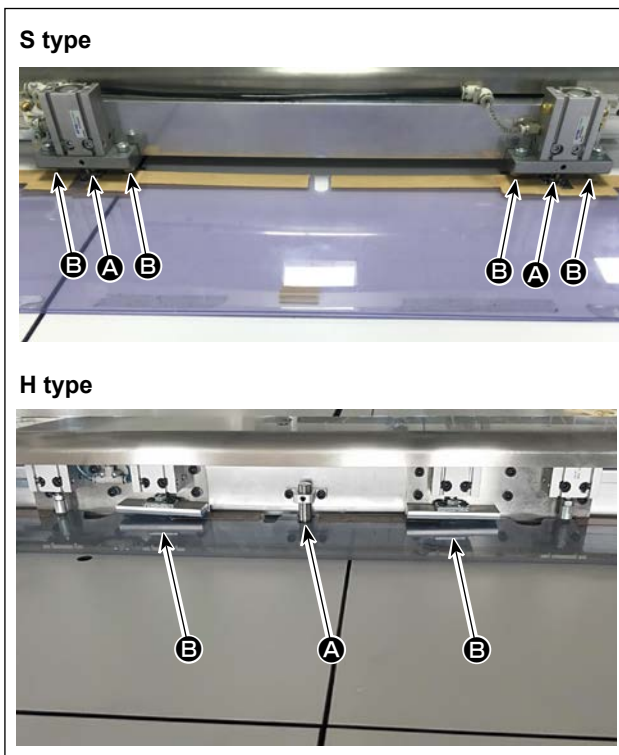

- 5) Attaching a pattern
Moving an empty pattern (with no material), fit positioning hole **A** on the pattern positioning plate on the positioning pin. Fit other two auxiliary positioning holes **B** on the positioning sleeves and fully push them until they will go no further.

6) Reading the sewing pattern data

1. In the case an IC card is attached to the pattern, activate the electronic scanner on the operation screen (refer to the Instruction Manual for the electrical system).
The electrical system automatically identifies the sewing pattern program that matches the pattern from those stored on the IC card
2. In the case no IC card is attached to the pattern, manually select the sewing pattern data that matches the relevant pattern on the operation screen.

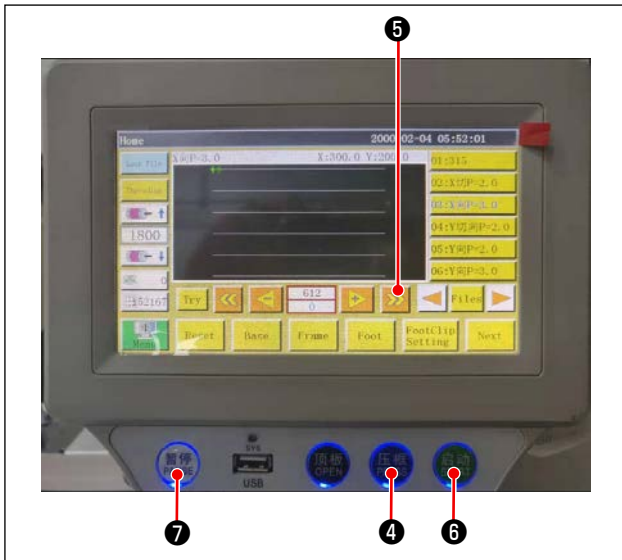

7) Selecting the reference

In order to align the locus of sewing pattern with the sewing slits of the pattern, it is necessary to set a reference. Specifically, set the reference referring to the Instruction Manual for the electrical system scanner.

After the completion of establishment of a reference, display the operation screen. When you keep button 5 held pressed, the pattern locus simulation sewing starts.

Operate the sewing machine once to check whether or not the sewing pattern locus is aligned with the pattern slits. If they are not aligned, re-adjust the reference.

To stop the operation while the simulation operation is being carried out, press button 7 to stop it.

8) Placing the material to be sewn

1. Detaching the pattern

When you move the pattern to the reset position and press clamp button 4 on the operation panel, two air cylinders on the X-direction linear module release the pattern. Take out the pattern.

2. Placing the material

Place the material to be sewn on the pattern. Then, check that the material is neatly arranged horizontally. In addition, secure the material with the holding method that matches the pattern to prevent the material from moving out of position. If the material has an infill of feather or cotton, squeeze the material to push out air as far as possible.

9) Setting the reset, pattern on which the material is placed, and the reference

- * Carry out resetting following the step of procedure 3).
- * Handling of the pattern on which the material is placed is described in the step of procedure 5).
- * Reference setting is carried out following the step of procedure 7).

10) Starting

Press the start button 6 on the operation panel to start sewing. Then, the sewing machine enters the automatic sewing mode.

11) Temporary stop

If any accident occurs during sewing, press the temporary stop button 7 on the operation panel. Then, the sewing machine immediately stops operation.

12) Re-starting

Once the aforementioned accident is eliminated, turn temporary stop button 7. Then, the button pops up and the emergency stop mode is reset. Then, press start button 6 to re-start automatic sewing.

4-23. Configuration of the operation panel

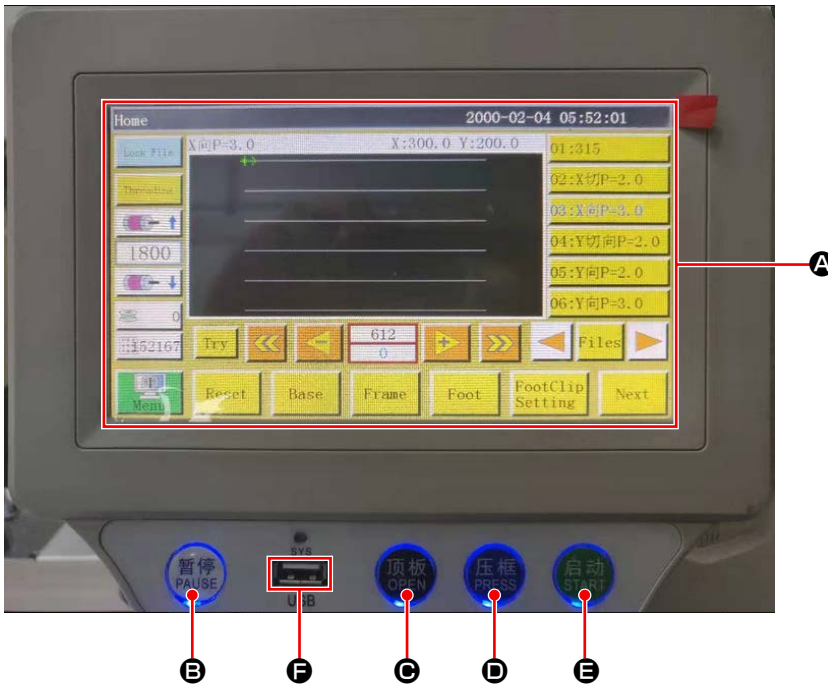

A	LCD portion of the touch panel	
B	PAUSE key	Used to temporarily stop sewing
C	OPEN key	Used to move up/down the top plate
D	PRESS key	Used to move up/down the cassette holder
E	START key	Used to start sewing
F	USB port	

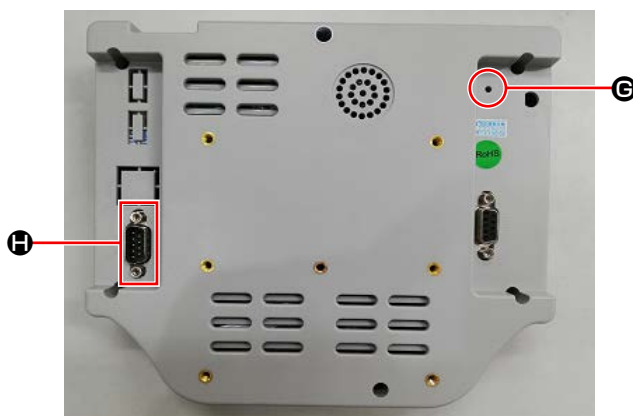

G	Reset button	Used to re-start the operation panel
H	COM port	RS232C

* This product is not provided with the Wi-Fi function.

Explanation of the operation panel screen

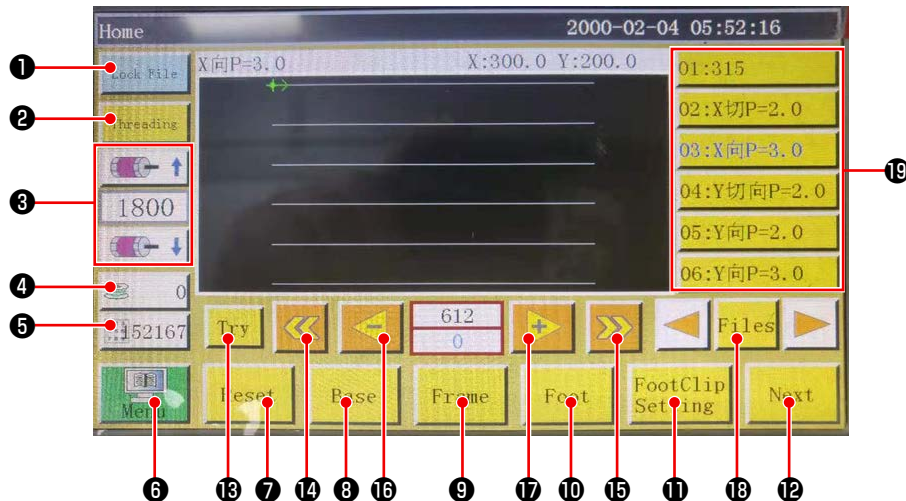

	Buttons / display	Description
①	Lock key	Used to lock the sewing pattern
②	Threading key	Used to thread the machine head
③	Main shaft speed change key	Used to change the sewing machine main shaft speed
④	Bobbin thread usage key	Used to display the amount of use of the bobbin thread and to move the screen to the setting screen *1
⑤	Sewing count key	Used to display the sewing count and to move the screen to the setting screen *1
⑥	Menu	Used to move the screen to the menu screen *1
⑦	Ready key	Used to return the sewing machine to its origin
⑧	Reference setting key	Used to move the screen to the reference setting screen *1
⑨	Cassette holder key	Used to move the cassette holder
⑩	Presser foot key	Used to operate the presser foot
⑪	Presser foot setting key	Used to move the screen to the presser foot setting screen *1
⑫	Page move key	Used to move the screen to the test mode screen *1
⑬	Test key	Used to operate the sewing pattern by jumping
⑭	Line segment return key	Used to return the sewing machine to the starting position of the previous continuous sewing by jumping
⑮	Line segment feed key	Used to feed the sewing machine to the starting position of the next continuous sewing by jumping
⑯	Single stitch return key	Used to return the sewing machine to the previous stitch. If this key is held pressed, fast-backward mode starts
⑰	Single stitch feed key	Used to feed the sewing machine to the next stitch. If this key is held pressed, fast-forward mode starts
⑱	File key	Used to move the screen to the sewing pattern selection screen
⑲	Sewing pattern selection	Select the sewing pattern to be used by touching it

*1. Refer to the Instruction Manual for the operation panel for details.

4-24. Maintenance mode

The maintenance mode is the mode under which the notice telling that the duration of use of the sewing machine has reached the time requiring maintenance is provided in order to extend the product life of the sewing machine. Under this mode, the maintenance screen is displayed on the operation panel. When the maintenance staff enters the user password, the maintenance screen is erased.

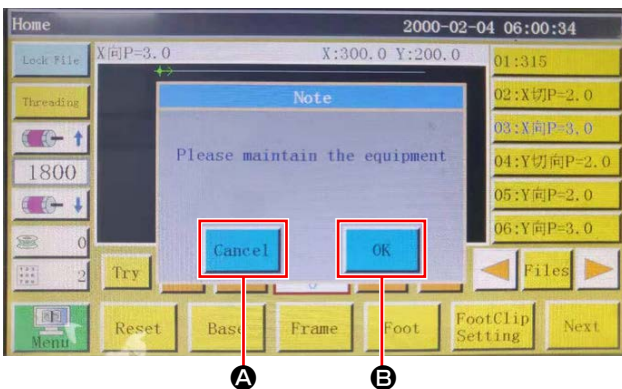
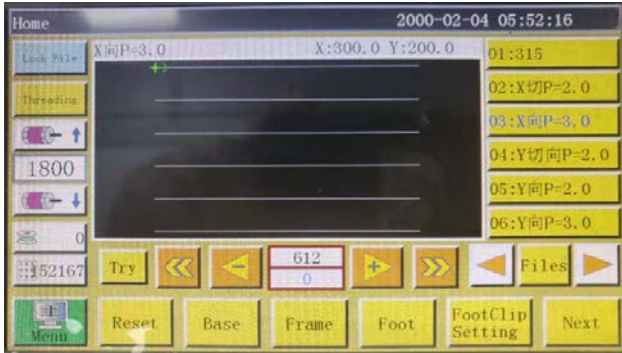

- 1) The maintenance screen is displayed when the time at which the sewing machine requires maintenance has come. (Approximately once every three months)

When cancel button **A** is pressed, the maintenance screen returns to the sewing screen. However, the maintenance screen is re-displayed one hour later.

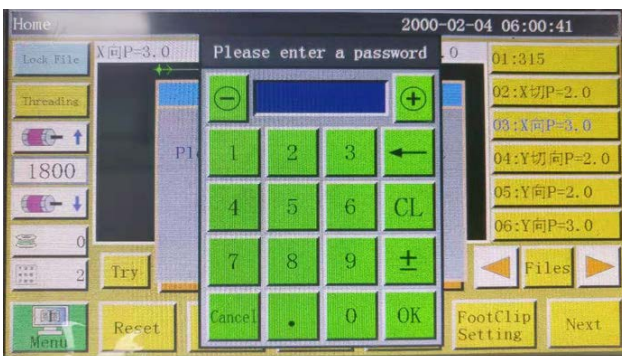

- 2) When enter button **B** is pressed, the user password input screen is displayed provided that the user password has been set up in prior.

- 3) Add grease referring to **"5. MAINTENANCE OF SAWING MACHINE" p. 51**.

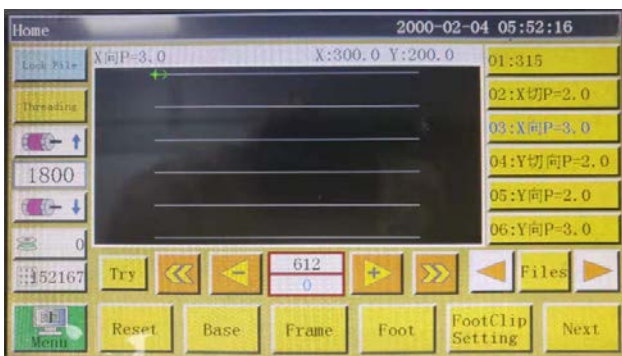

- 4) Enter the user password. Then, the maintenance screen returns to the sewing screen.

4-25. List of parameters

Classification of parameters	No.	Parameter name	Range	Standard value	Meaning of parameter and comment
Automatic machining	P1	Clamp is opened after the completion of automatic machining	Yes/No	Yes	Cassette clamp is lifted every time the continuous sewing cycle is completed
	P2	Number of stitches to be sewn at the beginning and end of sewing with the intermediate presser lowered	0 to 8	2	Number of stitches during which the intermediate presser presses the material at the beginning and end of sewing
	P3	Thread trimming after the completion of automatic machining	Yes/No	Yes	Thread trimming is carried out every time the continuous sewing cycle is completed.
	P4	Position to which the needle is returned after the completion of automatic machining	Origin / secondary origin	Origin	"Origin" is the origin of absolute coordinates.
					"Secondary origin" is the secondary origin (offset point) added to the pattern.
	P5	Whether or not the thread tension is required to be lowered	Yes/No	No	Whether or not the tension on the thread is loosened during jump
	P173	Clamp foot is retained when setting a reference	Yes/No	No	The clamp foot is retained while a reference is being set. On the "Main screen", keep the clamp foot held at its current position while moving the shaft. (Lifted or lowered) The "Main screen" is displayed after the operation panel is started up.
	P259	Automatic operation of the clamp	Yes/No	No	Whether the cassette clamp is turned ON at the beginning of sewing
	P240	Clamp operation in prior to the manual feed	Yes/No	No	Whether the cassette clamp is turned ON before the manual feed is carried out
	P6	Number of stitches to be sewn with overlapped at the beginning of sewing	OFF / 1 / 2	OFF	In the case of set value "1" or "2", sewing is carried out once or twice in repetition at the first needle entry position before proceeding to the next needle entry position at the time of starting the sewing machine. Setting of the number of reverse feed stitches at the beginning of sewing
					In the case of "OFF", the sewing machine does not repeat sewing
	P7	Number of stitches to be sewn at the beginning of sewing without the thread tension release mechanism	0 to 255	0	The thread tension release mechanism is turned OFF while the sewing machine sews the set number of stitches at the beginning of sewing
P147	Height of the intermediate presser when it is lowered at the beginning of sewing	0 to 4	0.5	Intermediate presser height at the beginning of sewing	
P148	Height of the intermediate presser when it is lowered at the end of sewing	0 to 4	0.5	Intermediate presser height at the end of sewing	

Classification of parameters	No.	Parameter name	Range	Standard value	Meaning of parameter and comment
Automatic machining	P161	Setting of the oscillating width of the presser foot at the beginning and end of sewing	Normal / half cut / increase	Normal	
	P172	Intermediate presser is reset after the completion of operation	Yes/No	Yes	Intermediate presser motor is reset at the end of sewing
	P248	Whether or not the shaft travel is required before setting a reference	Yes/No	Yes	
	P252	Clamp opening error at the time of setting a reference	Yes/No	No	
	P794	Output IO 1 at the end of operation	Yes/No	No	
	P796		High/Low	Low	
	P795	Output IO 2 at the end of operation	Yes/No	No	
	P797		High/Low	Low	
Startup speed	P8	First stitch startup speed (r/min)	100 to 3000	300	First stitch sewing speed
	P9	Second stitch startup speed (r/min)	100 to 3000	600	Second stitch sewing speed
	P10	Third stitch startup speed (r/min)	100 to 3000	900	Third stitch sewing speed
	P11	4th stitch startup speed (r/min)	100 to 3000	1500	4th stitch sewing speed
	P12	5th stitch startup speed (r/min)	100 to 3000	2100	5th stitch sewing speed
	P170	Number of revolutions of the reverse feed stitching (r/min)	100 to 3000	1200	Reverse feed stitching speed
	P13	Whether or not the soft start is required	Yes/No	Yes	Whether the machine is started at a low speed
	P162	Whether or not the soft start is required for the second stitch at the beginning of sewing	Yes/No	No	Whether the second stitch is sewn at a low speed
	P163	Whether or not the sewing speed reduction is required for two stitches at the end of sewing	Yes/No	No	Two stitches at the end of sewing are sewn at a low speed
	Speed parameter	P14	Maximum number of revolutions of the main shaft (r/min)	100 to 3000	S: 3000 H: 1800
P15		Jump speed (mm/min)	100 to 40000	20000	Jump speed
P916		Inching speed of the feed (mm/min)	100 to 20000	5000	Travel speed during correction and creation of patterns
P160		Trial stitching speed (mm/min)	100 to 60000	8000	Demonstration speed
P17		Button sewing speed 1 after the button is pressed (mm/min)	100 to 20000	500	Eight direction keys support the case of manual movement of the box or collection of files
					Operation speed using ► icon
P18		Button sewing speed 2 after the button is pressed (mm/min)	100 to 20000	1500	Eight direction keys are supported
	Operation speed using ►► icon				

Classification of parameters	No.	Parameter name	Range	Standard value	Meaning of parameter and comment
Speed parameter	P19	Button sewing speed 3 after the button is pressed (mm/min)	100 to 20000	8000	Eight direction keys are supported Operation speed using ►►► icon
	P174	Machine head 2 speed (mm/s)	0 to 2000	0	XY axes speed when using a laser knife
	P175	Machine head 3 speed (mm/s)	0 to 2000	0	XY axes speed when using a laser knife
	P178	Continuous inching speed	Reduce / minimum / normal	Reduce	Travel speed during pattern creation
	P773	Number of revolutions in the reverse direction (r/min)	100 to 3000	0	Reverse feed stitching speed
	P774	Number of stitches to be sewn at a limited speed at the end of sewing	0 to 30	0	Setting of the number of stitch from which the sewing speed is limited at the end of sewing a pattern
	P775	Limited sewing speed to be employed at the end of sewing	100 to 1800	0	This parameter is used in combination with P774 to obtain the specific limited speed value.
Clamp setting	P22	Prohibition of sewing during lifting of the clamp	Yes/No	Yes	Prohibition of sewing during lifting of the cassette clamp
	P25	Thread clamp starting angle at the beginning of sewing	1 to 990	10	Thread clamp ON angle at the beginning of sewing
	P26	Thread clamp ending angle at the beginning of sewing	1 to 990	10	Thread clamp OFF angle at the beginning of sewing
	P27	Thread clamp starting angle during thread trimming	1 to 990	15	Thread clamp starting angle during thread trimming
	P28	Thread clamp ending angle during thread trimming	1 to 990	180	Thread clamp ending angle during thread trimming
	P781	Whether or not the clamp is required during travel	Yes/No	No	
	P743	Delay in opening of the double clamp (ms)	0 to 5000	0	
	P744	Delay in lowering of the double clamp (ms)	0 to 5000	0	
Bobbin winder setting	P29	Bobbin winder status	Allowed / prohibited	Allowed	Bobbin winder  允许 Default state
	P30	Winding speed (r/min)	100 to 4500	2200	Bobbin winding speed
	P31	Bobbin winding time setting (s)	1 to 63000	200	Time setting of bobbin winding
Reset setting	P36	Clamp at the time of resetting	Yes/No	No	Cassette clamp comes down when returning to origin
	P264	Clamp is opened after manual resetting	Yes/No	Yes	Cassette clamp goes up when returning to origin by pressing the reset button
	P38	Return-to-origin method	XY simultaneous / X preference / Y preference	XY simultaneous	"xy simultaneous" means that the x and y axes are simultaneously reset to their origins. "x preference" means that the x axis is firstly reset to the origin, and "y preference" means that the y axis is firstly reset to the origin.

Classification of parameters	No.	Parameter name	Range	Standard value	Meaning of parameter and comment
Reset setting	P39	Return-to-origin speed (mm/min)	100 to 60000	15000	x, y axes speed during resetting to the origin
	P756-P761	Output I/O setting before resetting	OUT1 to OUT6 / Not set	Not set	Setting of IO before resetting
	P762-P797		High level / low level	High level	
	P649	Alarm in the case of a resetting error	Yes/No	No	
	P782-P787	Output IO setting after resetting	OUT1 to OUT6 / Not set	Not set	Setting of IO after returning to the origin
	P788-P793		High level / low level	High level	
Setting of stop	P40	Automatic thread trimming during temporary stop	Yes/No	Yes	Whether automatic thread trimming is performed at temporary stop
	P41	Needle position during temporary stop	Upper stop position / Lower stop position	Upper stop position	Needle bar position when temporary stop
	P45	Temporary stop switch type	Self lock / Normal	Self lock	Soft type of temporary stop, self-locking and normal
					"Normal" automatically bounces when touched
P799	Presser foot is not lifted during temporary stop	Yes/No	No		
Statistics settings	P49	Bobbin thread remaining amount is cleared at the time of turning the power ON	Yes/No	No	Whether the remaining amount of bobbin thread is reset to 0 (zero) when turning the power ON
	P50	Operation stops after the bobbin thread has run out	Yes/No	Yes	In the case of "Enable", the sewing machine stops when the consumed bobbin thread length has reached the "entire length".
	P51	Bobbin thread counter setting is enabled	Yes/No	Yes	In the case of "Set", statistics automatically indicate the consumed bobbin thread length
	P46	Bobbin thread counter is cleared at the time of turning the power ON	Yes/No	Yes	Whether the sewing counter is reset to 0 (zero) when turning the power ON
	P47	Operation continues after the counter has reached the set value	Yes/No	Yes	Whether the operation is continued after the sewing counter has reached the set value
	P48	Counter setting is enabled	Yes/No	Yes	Whether the sewing counter is enabled
	P52	Working hours counter	Yes/No	Yes	In the case of "Enable", the machining time statistics function is enabled
	P779	Bobbin thread count mode	IN1 to IN4 / default	Default	Statics mode of the bobbin thread amount
	P780	Adjustment value of the surplus amount of bobbin thread (mm)	0 to 600000	0	Adjustment of the bobbin thread remaining amount

Classification of parameters	No.	Parameter name	Range	Standard value	Meaning of parameter and comment
Thread clamp setting	P54	Thread clamp position at the beginning of sewing	0 to 200	0	Thread clamp position at the beginning of sewing
	P236	Laser output IO	Yes/No	No	Laser output
	P693	Enabling automatically changeable hook	Yes/No	No	
Detection of thread breakage	P55	Automatic detection of thread breakage	Yes/No	Yes	In the case of "Detect", the operation is stopped and the description of error is displayed. Thread breakage detection function
	P56	Neglect of detection of thread breakage	Provided / not provided	Provided	In the case of "Detect", thread trimming is automatically carried out after detection thread breakage Thread breakage is followed by thread trimming
	P57	Detection is ignored for the set number of stitches during sewing	1 to 255	3	For the number of stitches firstly set, thread breakage will not be detected
	P58	Detection of the effective number of stitches in the case of thread breakage	1 to 255	2	In the case thread breakage is detected continuously to reach the specified maximum number of broken stitches, it is assumed that thread has broken definitely.
	P237	Thread breakage output IO	Yes/No	No	
Thread breakage setting	P60	The number of revolutions of the thread trimmer main shaft (r/min)	10 to 500	260	Thread trimmer main shaft speed
	P61	Delay in the start of thread trimmer (s)	0.01 to 6.55	0.01	Delay time at the start of thread trimming
	P62	Continuous operating time of the wiper (s)	0.01 to 6.55	0.15	Wiper operating time
	P63	Delay in the lifting of presser foot after turning OFF the wiper (s)	0.01 to 6.55	0.25	Wiper OFF delay time
	P65	Whether or not the thread is trimmed during jump after sewing	Yes/No	Yes	Whether thread is trimmed at the time of jump
	P66	Whether or not the wiper is used	Yes/No	Yes	Whether the wiper is used
	P169	Thread slackening start mode	Angle / delay	Angle	Starting timing method for turning OFF the thread tension release mechanism
	P168	Thread slackening angle	0 to 999	850	Thread tension release mechanism turning-OFF angle
Energization setting	P70	The sewing machine is returned to the "stop with its needle up" state at the time of turning the power ON	Yes/No	Yes	Needle bar is at upper position when turning the power ON
	P71	Clamp is automatically returned to its origin at the time of turning the power ON	Yes/No	No	Cassette automatically returns to its origin when turning the power ON
	P73	Presser foot is lifted at the time of turning the power ON	Yes/No	Yes	Presser foot goes up when turning the power ON

Classification of parameters	No.	Parameter name	Range	Standard value	Meaning of parameter and comment
Other settings	P74	Whether or not the air pressure detection is required	Yes/No	No	In the case of "Enable", the sewing machine stops and generates the alarm if the detected air pressure is low during work
	P75	Whether or not the repetitive operation is required	Yes/No	No	"Enable" means that cyclic machining of the same file is started after turning the power ON
	P76	Repetitive machining time (min)	1 to 65535	1440	Cyclic machining total time: When the set time has elapsed, cyclic machining is stopped
Other settings	P77	Repetitive machining interval (s)	0 to 20	2	Interval from the completion of machining to re-starting of machining under the cyclic machining mode
	P78	Work ending position	Return to 0 (zero) / sewing starting position / default	Return to 0 (zero)	Return to 0 (zero): All of x / y axes coordinates return to 0 (zero); sewing machine terminates sewing; reset point
					Right side: Rightmost position within the machining range
					Sewing starting position: First sewing point of the machining file
	P395	Template recognition method	Barcode / electronic tag	Electronic tag	By serial number of file: Barcode identification mode
					By file name: Electronic tag identification mode
	P81	Interface style	Classic / simple	Classic	Classic: Button style of the virtual body
					Simple: Flat button style
	P681	Motion mode is started before operation	XY simultaneous / X precedence / Y precedence	XY simultaneous	
	P755	Jump mode during operation	X precedence / Y precedence / XY simultaneous	X precedence	Jump travel mode
P241	Connection to the extended screen	Yes/No	No	In the case of "Use", information on the operation file can be displayed on the external add-on display	
P79	Reverse feed after main shaft needle stops	0 to 160	0		
P242	Voice prompt	High / medium / low / OFF	OFF	"High", "medium" and "low" respectively refer to the magnitude of sound	
P21	Enabling the memory function during power failure	Enable / disable	Enable	After re-energization of the sewing machine, the sewing sequence carried out before power failure is resumed to continue sewing from that interrupted sequence.	
P194	The file is enabled upon separation of the electronic label	Enable / disable	Disable		

4-26. List of error codes

Error code	Error description	Solution
E001	No reset	Click the [Reset] button to reset.
E002	No X zero signal	Inspect the X sensor for poor contact or breakage
E003	No Y zero signal	Inspect the Y sensor for poor contact or breakage
E004	No Z zero signal	Inspect the Z sensor for poor contact or breakage
E005	No U zero signal	Inspect the U sensor for poor contact or breakage
E006	Extended shaft infinite bit signal	Inspect the shaft sensor for poor contact or breakage
E007	No spindle zero signal	Check the spindle encoder for breakage
E020	X axis overpressure	
E021	X axis undervoltage	
E022	X axis hardware overcurrent	
E023	X axis software overcurrent	
E024	X axis encoder failure	
E025	X axis open circuit	
E026	X axis overload	
E027	Position out of the X axis allowable range	
E028	X axis AD sampling failed	
E029	X axis overheat	
E030	Y axis overpressure	
E031	Y axis undervoltage	
E032	Y axis hardware overcurrent	
E033	Y axis software overcurrent	
E034	Y axis encoder failure	
E035	Y axis open circuit	
E036	Y axis overload	
E037	Position out of the Y axis allowable range	
E038	Y axis AD sampling failed	
E039	Y axis overheat	
E040	Z axis overpressure	
E041	Z axis undervoltage	
E042	Z axis hardware overcurrent	
E043	Z axis software overcurrent	
E044	Z axis encoder failure	
E045	Z axis open circuit	
E046	Z axis overload	
E047	Position out of the Z axis allowable range	
E048	Z axis AD sampling failed	
E049	Z axis overheat	
E050	Thread trimming shaft overpressure	
E051	Thread trimming shaft undervoltage	
E052	Thread trimming shaft hardware overcurrent	
E053	Thread trimming shaft software overcurrent	
E054	Thread trimming shaft encoder failure	
E055	Thread trimming shaft open circuit	

Error code	Error description	Solution
E056	Thread trimmer overload	
E057	Position out of the thread trimming shaft allowable range	
E058	Thread trimmer AD sampling failed	
E059	Thread trimming shaft overheat	
E060	Spindle overpressure	
E061	Spindle undervoltage	
E062	Spindle hardware overcurrent	
E063	Spindle software overcurrent	
E064	Spindle encoder failure	
E065	Spindle cannot rotate	
E066	Spindle rotation fault detected	
E067	Y servo hardware protection	
E068	Y servo HOC	
E069	Y servo AD module initial calibration fault	
E070	Y servo parameter storage exception	
E071	Y servo system parameter fault	
E072	Y servo AD sampling module failure	
E073	Y servo encoder disconnection	
E074	Y servo encoder AB interference	
E075	Y servo encoder Z interference	
E076	Y servo bus undervoltage	
E077	Y servo bus overvoltage	
E078	Y servo software overcurrent	
E079	Y servo motor overload	
E080	Y servo drive overload	
E081	Y servo motor overheat	
E082	Y servo drive overheat	
E083	Y servo fan fault	
E084	Y servo overspeed	
E085	Position out of the Y servo allowable range	
E086	Y servo bus voltage phase loss	
E087	Y servo motor phase sequence error	
E088	Y servo driver rated current input error	
E089	Y servo brake resistor overload	
E090	Y servo absolute encoder overheat	
E091	Y servo battery voltage is low	
E092	Y servo position information has been lost	
E093	Y servo drive does not match the motor	
E094	Y servo origin retrieval has failed	
E095	Y servo main power supply failure	
E096	Learning of the Y servo offset angle has failed	
E097	Y servo power OFF restart	
E098	Y servo initialization LAN9252 error	



Error code	Error description	Solution
E099	Communication between the Y servo DSP and ESC is interrupted	
E100	Communication between the Y servo network cable and host is interrupted	
E101	Exclusive for reading the Y servo PDO communication parameter	
E102	Y servo PDO communication has no index	
E103	Y servo PDO communication synchronization time is out of range	
E104	Y servo PDO communication data is out of range	
E105	Y servo UVW short circuit	
E106	Y servo inertia identification has failed	
E107	Y servo encoder EEPROM reading / writing has failed	
E108	Y servo positive position limit	
E109	Y servo position negative limit	
E110	Y servo electronic gear ratio range	
E111	Y servo input pulse frequency is too high	
E200	XY drive alarm	
E201	X drive alarm	
E202	Y drive alarm	
E203	Spindle returns to the initial position	
E204	Main motor direction is wrong	
E205	Pressure frame fails to come down	Click the "Press the frame" button to place the frame.
E206	Head board failure	The head plate has broken. It is necessary to change the broken head plate with a new one.
E207	Input I/O timeout error	Check whether the input IO has "high" or "low" of the input signal.
E208	Insufficient air pressure	Check whether the air supply unit supplies air normally.
E209	Clipper motor is not at the correct position	Check whether the zero signal of the clipper motor is normal.
E210	Presser motor is not at the correct position	Check that the zero signal of the presser foot motor is normal.
E211	Wire grab motor is not at the correct position	Check whether the zero line signal of the wire grab motor is normal.
E212	Cutter is not at the correct position	Check whether the zero signal of the cutter motor is normal.
E213	Wire breaks	Execute the thread again or turn OFF the wire break detection function before proceeding the operation.
E214	Number of jobs is too many	Counted value on the counter has reached the total number you have set. The total number on the counter is cleared and the counter re-starts counting by re-starting the operation.
E215	Bottom line has been already used up	It is necessary to change the bobbin thread hook.
E216	File size is too large	The number of pins in the graphics file has exceeded the maximum range. The current graphics file must be changed with a new one.

Error code	Error description	Solution
E217	Work file is not found	It is necessary to re-scan or change over the graphics file.
E218	Waiting for the work data	Queuing time for processing graphic data differs with the size of graphic
E219	Electrical failure. Contact the manufacturer.	Contact the manufacturer of the equipment
E220	Wrong upgrade file	It is necessary to replace the upgrade file with the new upgrade file.
E221	Error has occurred during upgrading of the file type	It is necessary to select the correct type of upgrade file for the file to be upgraded
E222	Not yet upgraded	Contact the manufacturer of the equipment
E223	It is not an upgrade file made by the same OEM	Contact the manufacturer of the equipment
E224	Cannot be connected to the head board	Inspect the head board for poor contact of the head board connection line and / or breakage of the desk head plate
E225	Connect to the main board	If the mother board for the display or the electric cord has broken though the screen line connection is neither poor nor broken, check that replacement of the broken part is necessary.
E226	The current file is not valid	It is necessary to change the graphics file if the graphical file has broken or the file is not intended to be used with this system type.
E227	File transfer has failed	If the mother board for the display or the electric cord has broken though the screen line connection is neither poor nor broken, check that replacement of the broken part is necessary.
E228	Data out of range	Check whether the current graphics file data is defective exceeding the ignorable range.
E229	This adjustment angle is too large	Corrected graphic angle is too large. Decrease the changed angle value.
E230	Reading of graphics	Process the necessary graphic data. Then, wait for a while before starting operation.
E231	Presser foot error	Check whether the presser foot motor is normal.
E232	U disk has not been detected	Re-insert the U disk or replace the U disk with a new one.
E233	File reading / writing error	① Replace the graphics file with a different one.
		② Re-insert the U disk or replace the U disk with a new one.
E234	Graphics out of range or head offset	① Reset the position of reference point.
		② Reset the offset value of the head 2 or head 3.
		③ Replace the small-width graphic with the normal-width graphic.
E235	This file is not a file to be processed	Replace the graphics file with a different one.
E236	Ferroelectric damage	Contact the manufacturer of the equipment
E237	Set an administration password	Firstly, set the administration password.
E238	Edit is not supported	Command or file that is not required to be edited
E239	Contact the manufacturer	Contact the manufacturer of the equipment
E240	Communication fault 2	CAN communication error has occurred, or the mother-board program is old one.
E241	At the time of fault	① Time has been modified illegally.
		② Motherboard battery voltage is low.

Error code	Error description	Solution
E242	No job IO	① Work enable input IO signal is abnormal.
		② Shut down the "Work enable input IO" function. Set the parameter value to 0 (zero).
E243	Input waiting IO	Waiting for the input IO signal in the graphics file.
E244	Delay is executed	Delay command is executed with the graphics file.
E245	File name is too long	It is necessary to shorten the file name.
E246	Lift the presser foot in advance	It is necessary to lift the presser foot by clicking the "Presser foot" button.
E247	Frame is not pressed	It is necessary to press the frame in advance.
E248	Auxiliary pressure frame is not pressed	It is necessary to firstly press the auxiliary pressure frame.
E249	Pressure frame and auxiliary pressure frame are not pressed	It is necessary to push down all of the back pressure blocks.
E250	Punched bottom material has run out	It is necessary to replace the material to be punched with a new one.

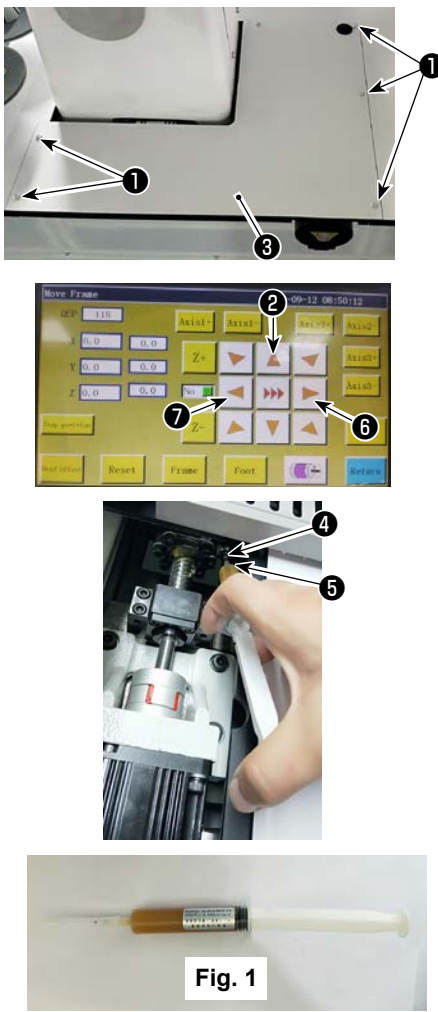
5. MAINTENANCE OF SAWING MACHINE

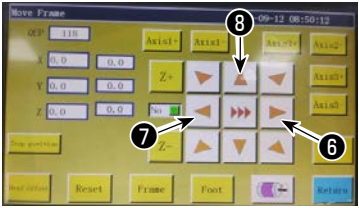
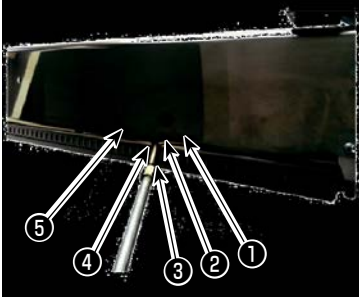
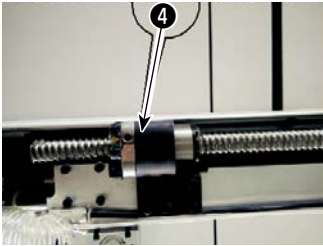
No.	Region	Explanation	Operating time
1	<p>The area under the throat plate, area surrounding the hook, bobbin case and its inner portion, thread trimming area, needle bar area, areas inside and outside of the presser foot, openings of the electronic control box such as air inlet and outlet, and the regions in which thread waste, thread end and other stains are likely to remain.</p> 	<p>Clean up the surface of equipment with a tool such as an air gun. In particular, clean up the regions in which the aforementioned thread waste, thread end and other stains are likely to remain.</p>	<p>Eight hours</p>
2	<p>Lubricate the machine through the Y-direction ball screw nut oil hole.</p>  <p style="text-align: center;">Fig. 1</p>	<ol style="list-style-type: none"> 1. Remove screw ❶ . Detach mid-plate back cover ❸ . 2. Enter the manual frame travel screen from the operation panel. Press key ❷ to move the X-direction linear module backward. In addition, move oil hole ❹ on the Y-direction ball screw nut to the lower side of the middle plate rear cover. 3. Aligning tip ❺ of grease-filled syringe (in Fig. 1) with oil hole ❹ , add oil through the oil hole. 4. Lubricate each portions requiring lubrication at least five times. The oil amount for each portion should not fall below 5cm³. 5. Every time the grease is added through oil hole, press key ❻ and ❼ several times to move the Y ball screw nut back and forth to spread the lubricating oil over the clearance between balls. 6. After the completion of lubrication, check to make sure that the grease exudes between the ball screw and the nut. 7. After the completion of lubrication, move the rear cover of the middle plate to its home position, and tighten screw ❶ . 8. Lithium based grease No. 2 should be used as lubricating grease. Do not use it with mixed with other type of lubricating grease. 	<p>According to the usage environment, the sewing machine may sew 100 million stitches. (Lubrication should be carried out when one of the following conditions has been reached.) When the sewn number of stitches has reached 100 million stitches; or When the sewing machine has been used for three months</p>

No.	Region	Explanation	Operating time
3	<p>Lubricate the machine through X-direction ball screw nut oil hole.</p>    	<ol style="list-style-type: none"> 1. Detach rubber plug ❶ . 2. Enter the frame travel screen from the operation panel. Press key ❷ to move the pattern presser device on the X-direction linear module to the left. In addition, move oil hole ❸ on the X-direction ball screw nut to the underside of hole ❷ in cover ❸ . 3. Aligning syringe tip ❸ with filler port ❹ , squeeze the syringe to add oil through the oil hole. 4. Lubricate each portions requiring lubrication at least five times. The oil amount for each portion should not fall below 5cm³. 5. Every time the grease is applied through oil hole, press key ❹ and ❺ several times to move the X ball screw nut to the right and left to spread the lubricating oil over the clearance between balls. 6. After the completion of lubrication, check to make sure that the grease exudes between the ball screw and the nut. 7. After the completion of lubrication, return rubber plug ❶ to its original position. 8. Lithium based grease No. 2 should be used as lubricating grease. Do not use it with mixed with other type of lubricating grease. 	<p>According to the usage environment, the sewing machine may sew 100 million stitches. (Lubrication should be carried out when one of the following conditions has been reached.)</p> <p>When the sewn number of stitches has reached 100 million stitches; or</p> <p>When the sewing machine has been used for three months</p>

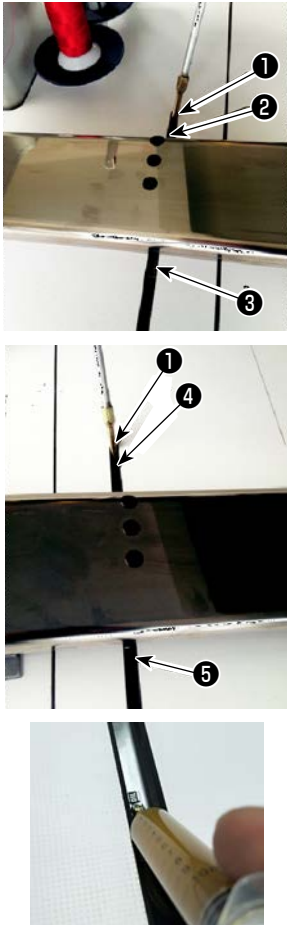
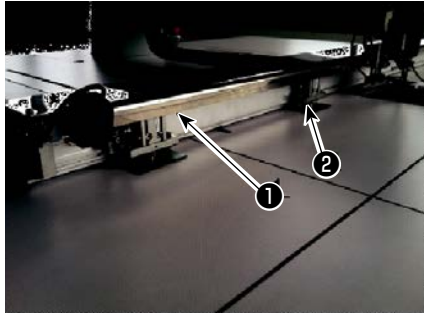
No.	Region	Explanation	Operating time
4	<p>Lubricate two Y-direction linear guide sliders through their four oil holes.</p> 	<ol style="list-style-type: none"> 1. Aligning needle tip ① with Y-direction linear guides ② , ③ , ④ and ⑤ , squeeze the syringe to add oil to the oil hole of the respective linear guides. 2. Lubricate each portions requiring lubrication at least five times. The oil amount for each portion should not fall below 5cm³. 3. Every time the grease is applied through the oil hole, press the slider on the linear guide several times to spread the grease over the clearance between balls. 4. After a sufficient amount of grease is added, check to make sure that the grease exudes between the ball screw and the nut. 5. Lithium based grease No. 2 should be used as lubricating grease. Do not use it with mixed with other type of lubricating grease. 	<ol style="list-style-type: none"> 1. Replenish the machine with lubricating grease again after the equipment has run 6400 km or for five years. 2. According to the environment of usage, apply the lubricating grease once every three months or when the sewing machine has sewn 100 million stitches after the first lubrication.
5	<p>Apply oil to two oil holes of the X-direction linear guide sliders.</p> 	<ol style="list-style-type: none"> 1. Aligning the tip of syringe with oil holes ① and ② , squeeze the syringe to respectively add oil through oil holes ① and ② until oil they are filled with oil once. 2. Lubricate each portions requiring lubrication at least five times. The oil amount for each portion should not fall below 5cm³. 3. Every time the grease is added through the oil hole, press the slider on the linear guide several times to spread the grease sufficiently over the clearance between balls. 4. After a sufficient amount of grease is added, check to make sure that the grease exudes between the linear guide and the slider. 5. Lithium based grease No. 2 should be used as lubricating grease. Do not use it with mixed with other type of lubricating grease. 	<ol style="list-style-type: none"> 1. Replenish the machine with lubricating grease again after the equipment has run 6400 km or for five years. 2. According to the environment of usage, apply the lubricating grease once every three months or when the sewing machine has sewn 100 million stitches after the first lubrication.

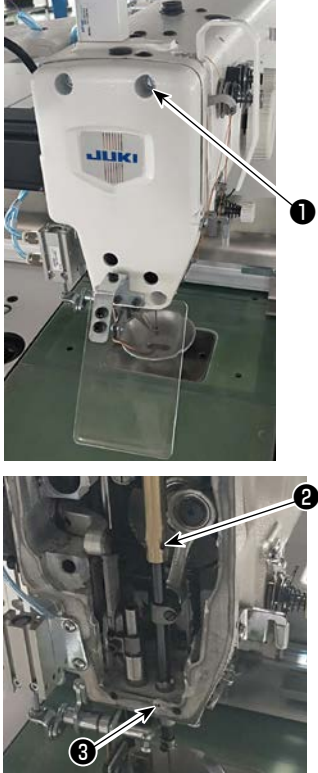
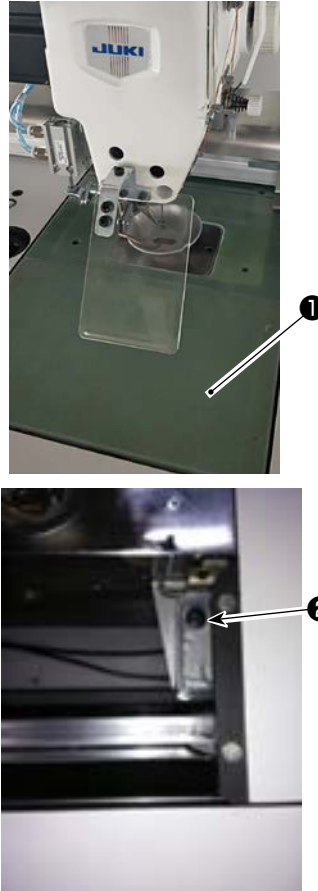
No.	Region	Explanation	Operating time
6	<p>Apply grease to the upper and lower covers of needle bar, needle bar slide groove, guide frame groove of the presser bar, presser bar, etc.</p> 	<ol style="list-style-type: none"> 1. Loosen screw ❶ of the face plate. Detach the face plate. 2. Loosen and remove screw ❷ of the needle bar upper bushing and ❸ of the needle bar lower bushing. 3. Align the grease gun oil hole with tapped holes ❷ and ❸ of the upper and lower bushings of the needle bar to lubricate. 4. The oil amount to be added should not fall below 0.5cm³. 5. After the completion of lubrication, tighten the screws of upper and lower bushings of the needle bar. 6. At the same time, apply an appropriate amount of grease to the needle bar slide groove, needle bar guide frame groove, presser bar, etc. 7. Lithium based grease No. 2 should be used as lubricating grease. Do not use it with mixed with other type of lubricating grease. 	<ol style="list-style-type: none"> 1. Replenish the machine with lubricating grease again after the equipment has run 6400 km or for five years. 2. According to the environment of usage, apply the lubricating grease once every three months or when the sewing machine has sewn 100 million stitches after the first lubrication.
7	<p>Lubricate the hook oil tank.</p> 	<ol style="list-style-type: none"> 1. Detach cover ❶ . 2. Remove rubber plug ❷ of the oil tank. 3. Pour accessory (or specified) oil to the oil tank through the rubber plug hole. 4. When the oil amount in the oil tank reaches the upper scale mark, stop pouring oil. 5. Return the rubber plug to and return the cover to their original positions. 	<p>If the oil level in the oil tank drops below the lower scale marker, replenish the oil tank with the accessory (or specified) oil.</p>

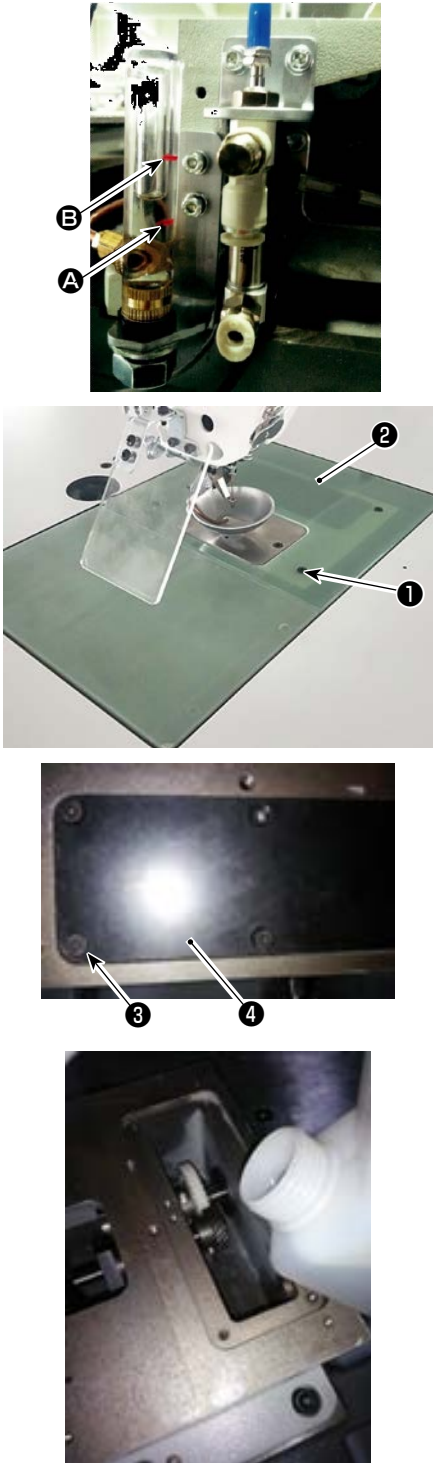
No.	Region	Explanation	Operating time
8	<p data-bbox="240 163 681 226">Adding the lubricating oil to the gear box.</p> 	<ol style="list-style-type: none"> <li data-bbox="697 163 1121 297">1. Remove four screws ① . Detach hook cover ② . Remove six screw ③ . Detach gear box cover ④ and gasket. <li data-bbox="697 304 1121 367">2. Pour No. 32 white oil to the gear box little by little. <li data-bbox="697 374 1121 472">3. When the oil amount reaches the upper scale mark ③ of the oil level gauge, stop pouring oil. <li data-bbox="697 479 1121 613">4. Return the cover and gasket of the gear box, and hook cover to their original positions. Tighten the screw. 	<p data-bbox="1137 163 1442 367">Replenish the gear box with No. 32 white oil if the oil surface shown on the level gauge falls below the lower scale mark ①.</p>

5-1. Troubles and corrective measures (Sewing conditions)

Trouble	Cause	Corrective measures
1. The needle thread slips off at the start of bar-tacking.	<ul style="list-style-type: none"> ① Stitches are slipped at the start. ② The needle thread remaining on the needle after thread trimming is too short. ③ The bobbin thread is too short. ④ Needle thread tension at 1st stitch is too high. ⑤ Stitching pitch at 1st stitch is too small. 	<ul style="list-style-type: none"> ○ Adjust the clearance provided between the needle and the hook. ○ Set soft-start sewing at the beginning of sewing. ○ Decrease the tension of the thread tension controller No. 1. ○ Increase the tension of the thread take-up spring. ○ Decrease the bobbin thread tension. ○ Increase the clearance between the needle and the counter knife. ○ Decrease the needle thread tension at 1st stitch, and extend the duration of the AT operation at the beginning of sewing. ○ Make the stitching pitch at 1st stitch longer. ○ Decrease the needle thread tension at 1st stitch.
2. Thread often breaks or synthetic fiber thread splits finely.	<ul style="list-style-type: none"> ① The hook or the inner hook holder has scratches. ② The needle hole guide has scratches. ③ Thread enters the groove in the hook. ④ The needle thread tension is too high. ⑤ The tension of the thread take-up spring is too high. ⑥ The synthetic fiber thread melts due to heat generated on the needle. ⑦ When taking up the thread, the needle tip penetrates the thread. 	<ul style="list-style-type: none"> ○ Remove the hook and grind hook or the inner hook holder with a fine grind stone or buff them. ○ Buff the needle hole guide or replace it with a new one. ○ Detach the hook to remove the thread. ○ Decrease the needle thread tension. ○ Decrease the tension of the thread take-up spring. ○ Use the optional needle cooler. ○ Check the rough state of needle tip. ○ Use the ball-pointed needle.
3. The needle often breaks.	<ul style="list-style-type: none"> ① The needle is bent. ② The needle comes in contact with the intermediate presser. ③ The needle is too thin for the material. ④ Clearance between the needle and the hook is too small. 	<ul style="list-style-type: none"> ○ Replace the bent needle. ○ Adjust the position of the intermediate presser. ○ Replace it with a thicker needle according to the material. ○ Adjust the clearance between the needle and the hook.
4. Threads are not trimmed. (Bobbin thread only)	<ul style="list-style-type: none"> ① The counter knife is dull. ② Knife pressure of the counter knife is low. ③ The counter knife has been improperly positioned. ④ The last stitch is skipped. ⑤ Bobbin thread tension is too low. ⑥ Flopping of cloth 	<ul style="list-style-type: none"> ○ Replace the counter knife. ○ Adjust the knife pressure of the counter knife. ○ Correct the position of the counter knife. ○ Correct the timing between the needle and the hook. ○ Increase the bobbin thread tension. ○ Lower the intermediate presser height.
5. Stitch skipping often occurs.	<ul style="list-style-type: none"> ① Clearance provided between the needle and the hook is not correct. ② Position of the inner hook holder against the needle is not correct. ③ The needle is bent. ④ The needle thread after thread trimming is too long. 	<ul style="list-style-type: none"> ○ Adjust the clearance between the needle and the hook. ○ Adjust the position of the inner hook holder against the needle. ○ Replace the bent needle. ○ Decrease the tension of the thread take-up spring. ○ Increase the tension of the thread tension controller No. 1.
6. The needle thread comes out on the wrong side of the material.	<ul style="list-style-type: none"> ① The needle thread tension is not high enough. ② The needle thread after thread trimming is too long. 	<ul style="list-style-type: none"> ○ Increase the needle thread tension. ○ Increase the tension of the thread tension controller No. 1.
7. Threads break at time of thread trimming.	<ul style="list-style-type: none"> ① The knife has been improperly position. 	<ul style="list-style-type: none"> ○ Correct the position of the knife.

Trouble	Cause	Corrective measures
8. Thread end of the 1st stitch comes out on the right side of the material.	<ul style="list-style-type: none"> ① Stitch skipping at the 1st stitch. ② Needle used and thread used are thick in terms of the inner diameter of the intermediate presser. ③ Intermediate presser is not properly positioned in terms of the needle. ④ The direction of air blower is incorrect. As a result, needle thread at the tip of needle cannot be clamped with the disc presser. 	<ul style="list-style-type: none"> ○ Increase the length of needle thread remaining at the needle after thread trimming. ○ Change the current intermediate presser with another one which has a larger inner diameter. ○ Adjust the eccentricity between intermediate presser and needle so that needle enters in the center of intermediate presser. ○ Adjust the air-blowing direction of the air blower according to the direction of sewing so that the needle thread at the tip of needle can be clamped with the disc presser.
9. The needle thread is entangled in the inner hook holder.	<ul style="list-style-type: none"> ① The clearance provided between the inner hook holder and the inner hook is too small. 	<ul style="list-style-type: none"> ○ Adjust the clearance provided between the inner hook holder and the inner hook appropriately according to the thickness of needle thread to be used.
10. The knotting section of bobbin thread at 2nd stitch at the sewing start appears on the right side.	<ul style="list-style-type: none"> ① The bobbin runs idle excessively. ② Bobbin thread tension is too low. ③ The needle thread tension at 1st stitch is too high. 	<ul style="list-style-type: none"> ○ Adjust the height of idling prevention spring of the bobbin case appropriately. ○ Increase the bobbin thread tension. ○ Decrease the needle thread tension at 1st stitch.

5-2. Disposal of batteries



The operation panel has a built-in battery in order to operate the clock even when the power is turned OFF. Be sure to dispose of the battery following the local laws and regulations.

■ How to remove the battery



1) Release lock ① of the door at the back or side face of the sewing machine to open the door.

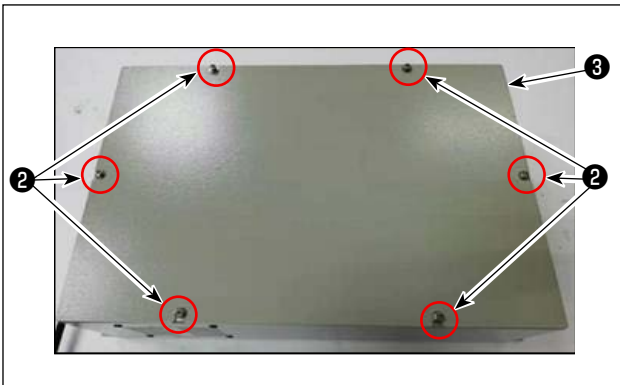

2) Remove cover setscrews ② of electrical box ③ that is located inside the door. Then, detach the front cover of the electrical box.

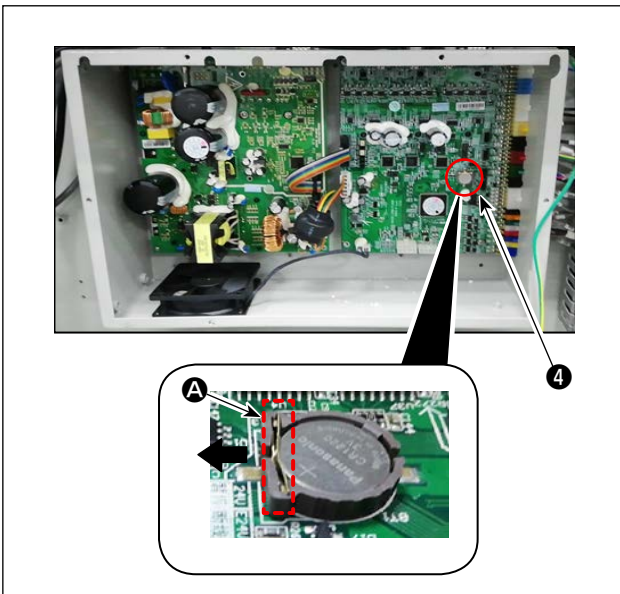

3) Slide stopper A of battery ④ in the direction of the arrow to detach battery ④ .

6. SUBCLASS MODEL

6-1. Barcode reader



WARNING :

Be sure to turn OFF the power supply and air supply to the sewing machine before attaching the parts in order to protect against accidents caused by an unintended start of the sewing machine.

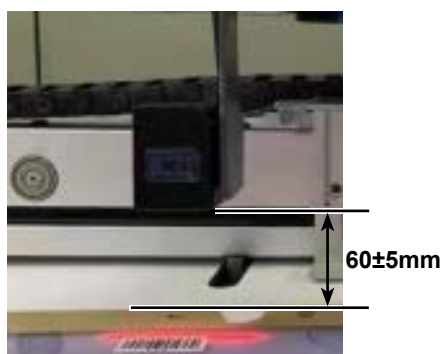
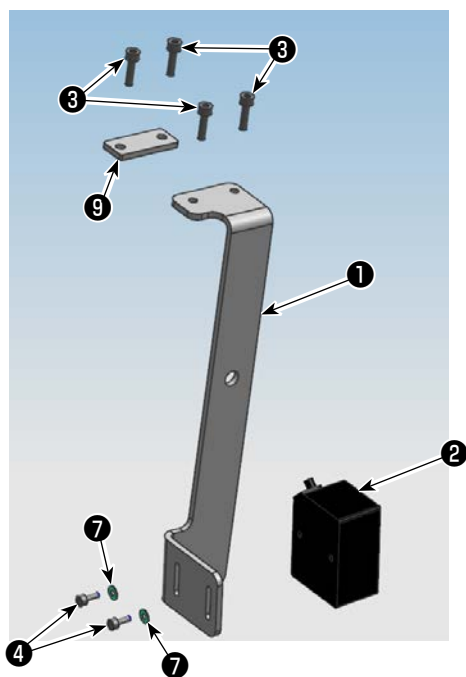

1. Installing the parts

- 1) Secure barcode reader ② and mounting plate ① with screw ④ .

No.	Part number	Part name	Quantity
①	40234788	Barcode reader mounting plate	1
②	40235199	Barcode reader	1
③	40234468	Screw	4
④	40235200	Screw	2
⑤	40235332	Cable clip band	1
⑥	40235331	Barcode	1
⑦	40234514	Washer	2
⑧	40240831	Mounting plate	1

- 2) Detach screws ⑨ (four pieces) of the operation panel mounting base. Install mounting plate ① under the operation panel mounting base with screws ③ (two pieces).
Install mounting plate ⑧ under the operation panel mounting base with screws ③ (two pieces).

- 3) Adjust the position of barcode reader ② so that it is spaced 60 ± 5 mm. Then, secure it with screw ④ . Connect the plug of barcode reader to the panel. Pass cable clip band ⑤ through the hole in mounting plate ① and bundle the barcode reader cable with the cable clip band.



When bundling the barcode cable, slightly loosen the cable near the barcode reader.

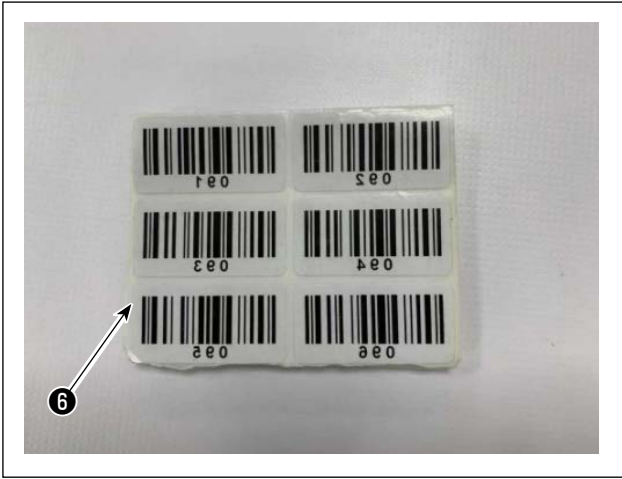

4) Take out a seal from barcode seals ⑥ provided.

 One hundred barcode seals (with serial numbers from 001 to 100) are provided.

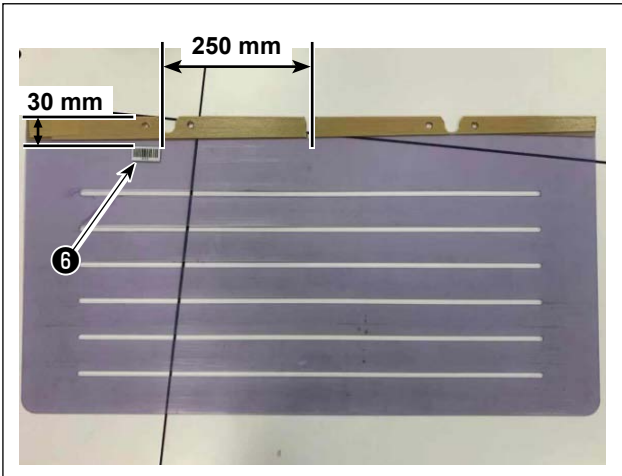

5) Stick the barcode seal to the cassette at the position that is 250 mm left from the center of cassette (setup guide) and 30 mm below the upper side of cassette.

 The aforementioned sticking position is recommended. It is acceptable to stick the barcode seal at any position that will not interfere with the recognition of the barcode seal by the barcode reader.

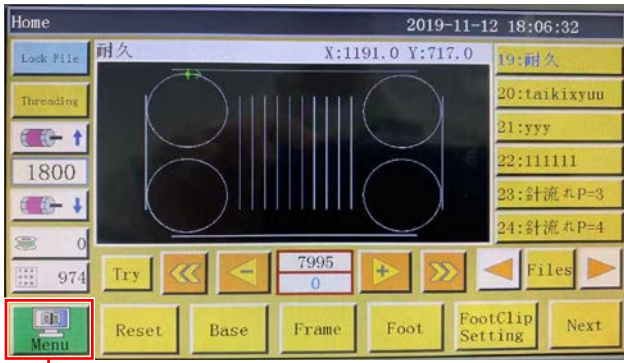

A

2. Setting the barcode functions

● Setting the barcode functions on the operation panel

1) Press button **A**.

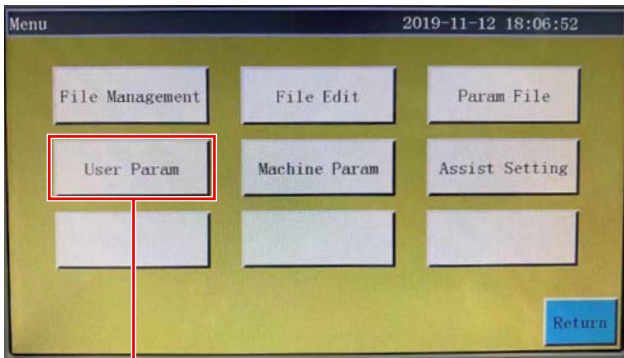

B

2) Press button **B**.

In the default state, the factory-set password is provided. The password is "11111111".

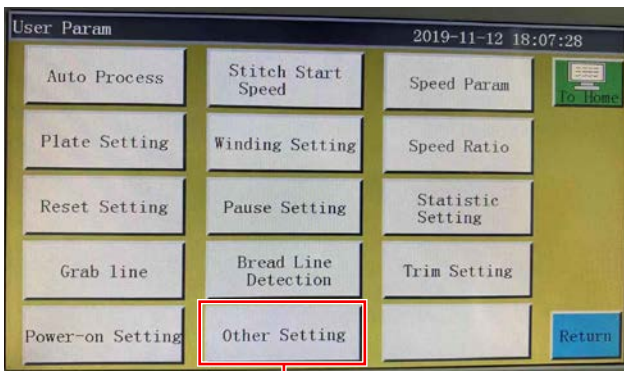

C

3) Press button **C**.

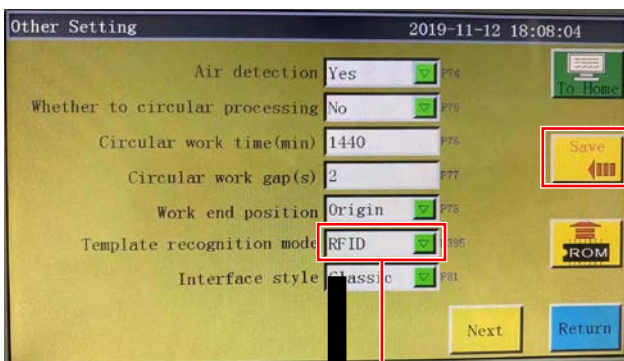

4) To allow the barcode reader to recognize the template, change **D** from "Electronic identification label" to "Barcode".

Then, press **E**.

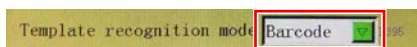

D

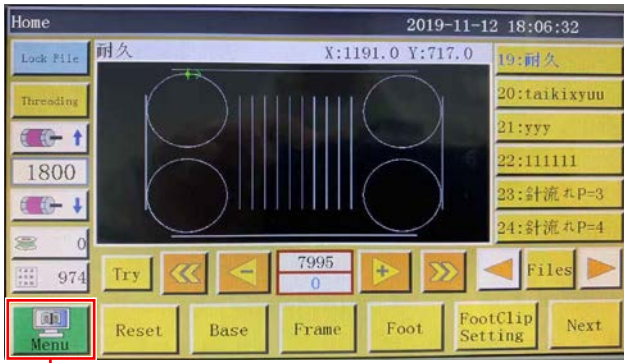

● Setting the barcode number

1) Press button **A**.

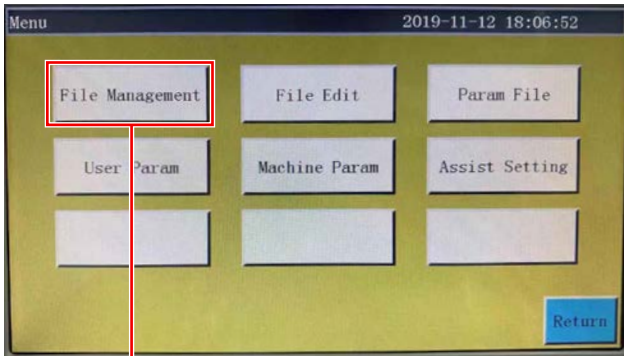

2) Press button **B**.

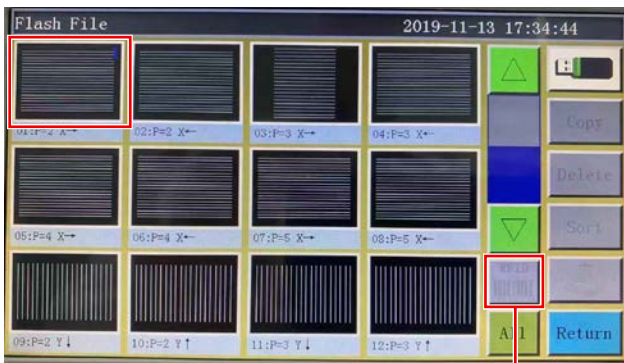

3) Select the sewing pattern file you want to read and press button **C**.

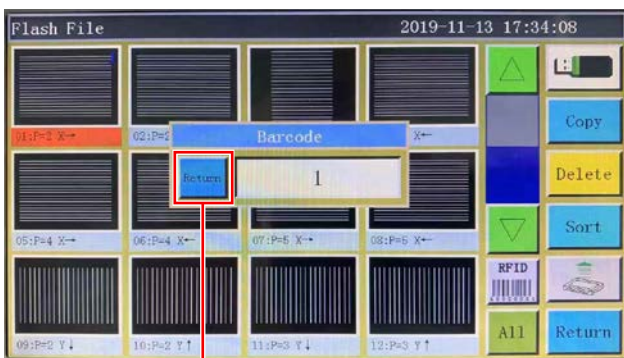

4) Press button **D**.
Save the data.

● Cancelling the barcode number

When you want to cancel the barcode reader number, it is necessary to set the current number to the largest value (the largest one of unassigned numbers, such as 100) first. Then, change that number to "0".

Example)

1	2	3	4	5	6
		↓			
		0			

1	2	3	4	5	6
		↓			
		7 (or 8 to 100)			

When the number "3" is changed to "0", the subsequent numbers registered "4, 5 and 6" will also be erased.

To prevent the aforementioned erasure of registered numbers you do not want to erase, firstly set the barcode number to the largest available value "7", then change it to "0".

● How to use the barcode reader

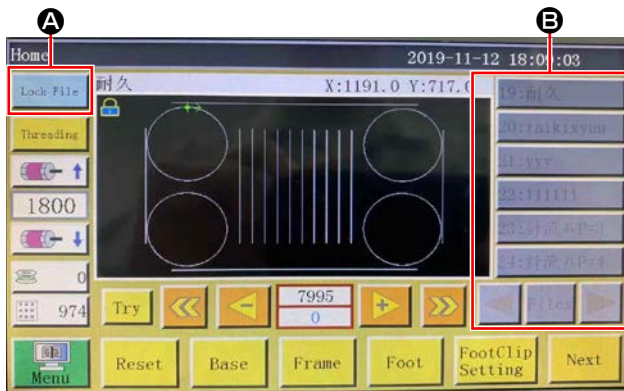

1) Press button **A** to lock the pattern conversion.

Caution
The barcode is enabled by locking the pattern conversion. When the pattern conversion is locked, pattern list **B** changes its color to gray.



2) Place the barcode seal in the cassette right under the barcode reader.

When the barcode reader recognizes the barcode, the barcode reader beeps.

Caution
If the barcode reader does not beep, adjust the vertical position of the barcode reader. If the pattern is not converted even when the barcode reader beeps, check the self lock.



3) Check whether the pattern is converted appropriately.

6-2. Rotary knife

6-2-1. Safety precautions

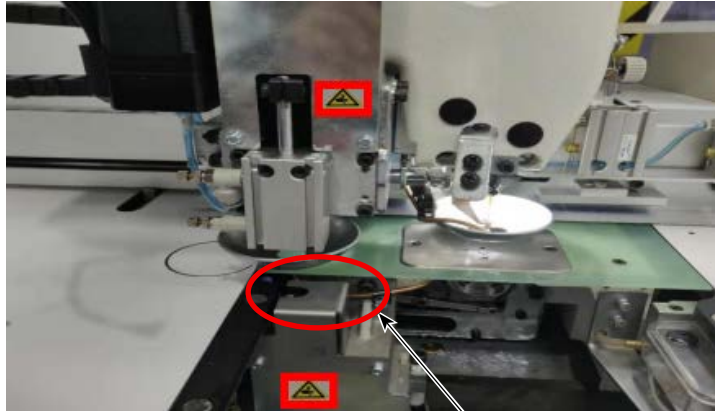

Putting a hand here is prohibited in order to protect against cuts and laceration.



1. Anyone other than the workers (persons concerned) is prohibited from touching the machine during installation and adjustment procedures.
2. Keep your hands away from the moving parts in order to protect against cuts while the knife is in operation.
3. Direct contact with the blade point of the counter knife and moving knife is prohibited in order to protect against scrapes and scratches.

6-2-2. How to carry out coaxial adjustment

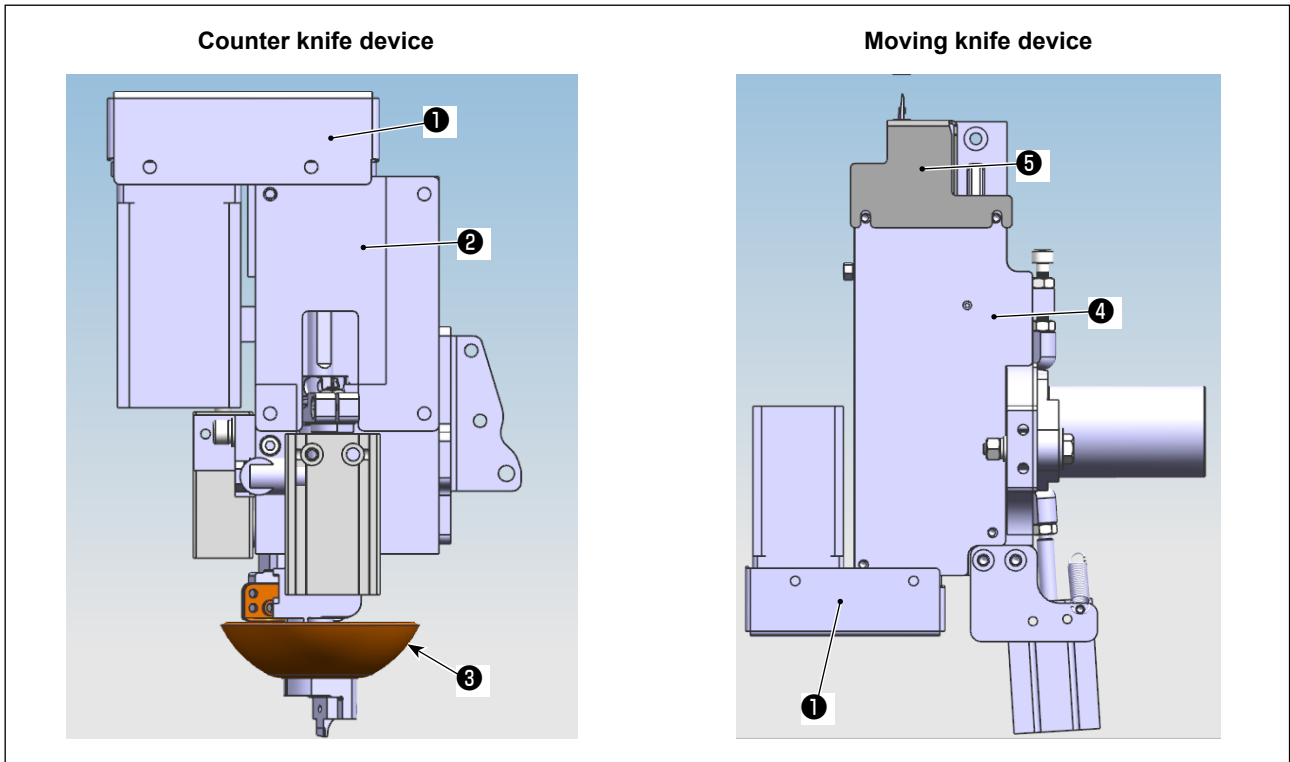

- 1) Turn OFF the power and air.
- 2) Detach upper fixing plate ② , lower fixing plate ④ , timing belt cover ① , moving knife cover ⑤ and knife clamp ③ .

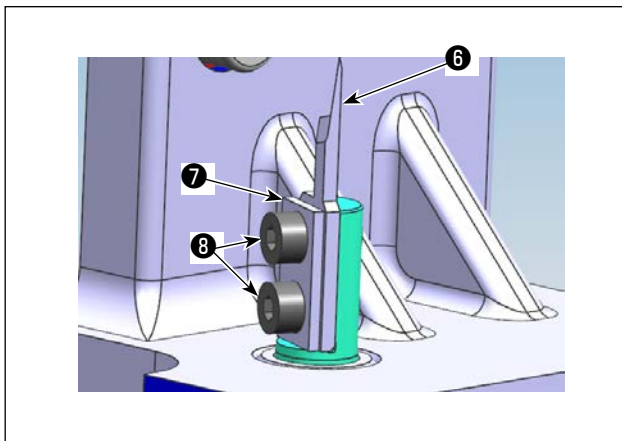

- 3) Detach the moving knife components (clamp plate ⑦ (one piece), one moving knife ⑥ (one piece) and setscrews ⑧ (two pieces)).

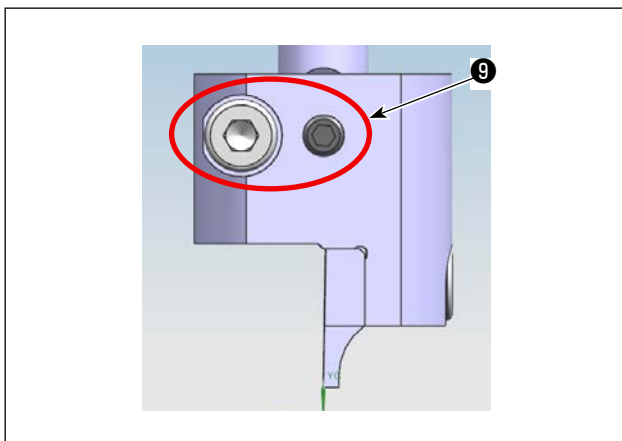

- 4) Loosen setscrews ⑨ (two pieces). Detach the counter knife asm.

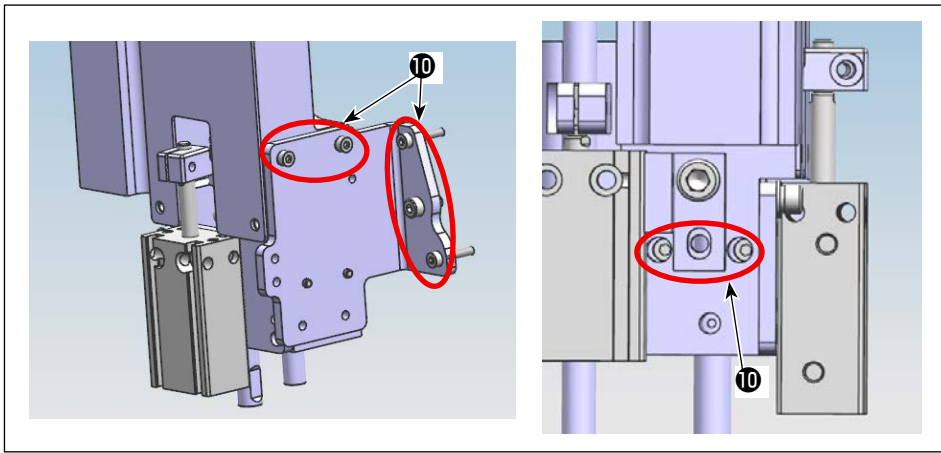

5) Loosen setscrews **10** (seven pieces) of the counter knife unit.

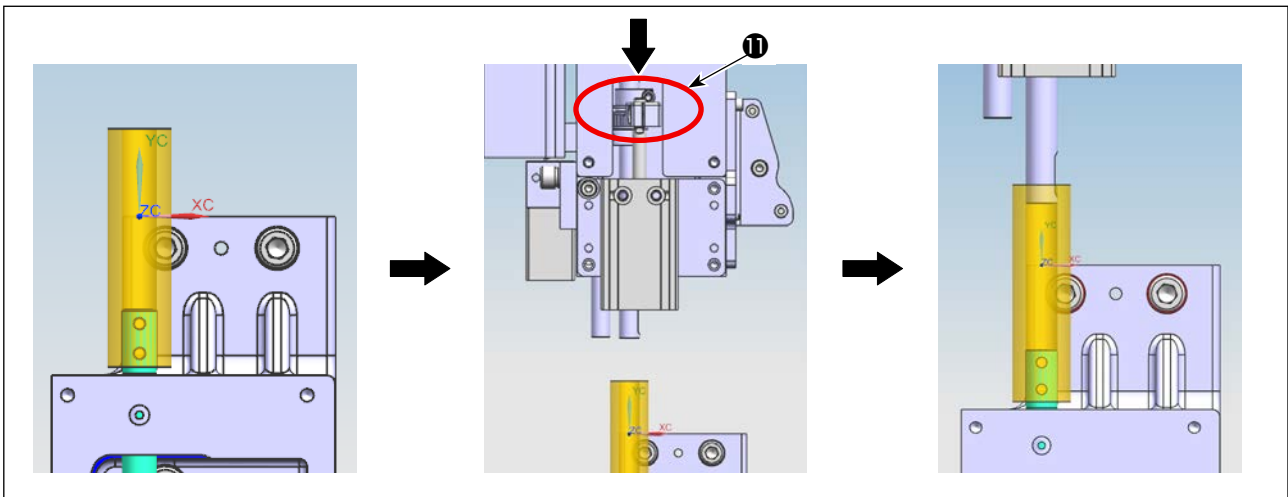

6) Fit the bushing jig into the moving knife shaft. Push down link **11** of the counter knife unit to put the counter knife shaft into the bushing jig.

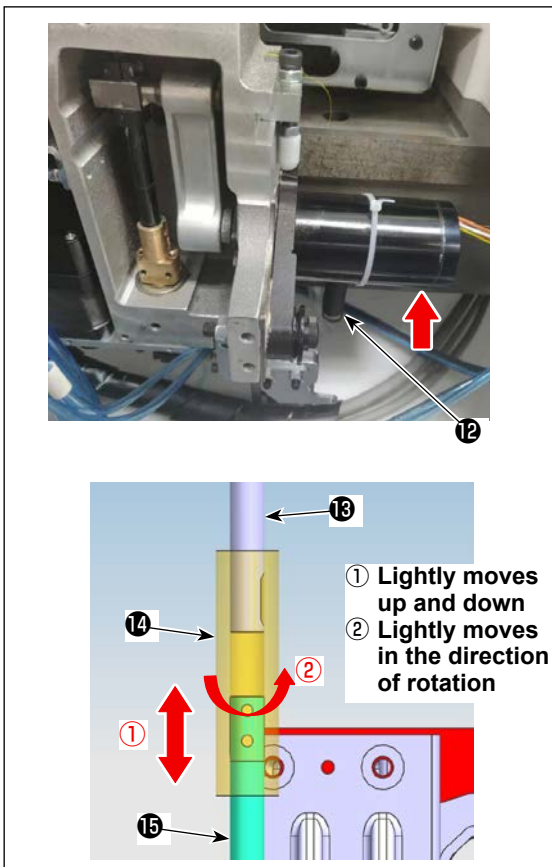

7) Remove reposition spring **12** of the moving knife. Lift up the drive motor.

8) Lifting bushing jig **14** while taking care to prevent it from interfering with the flat portion of moving knife shaft **15** / counter knife shaft **13**, adjust the position of the counter knife unit so that the bushing shaft lightly moves up and down and also lightly moves in the direction of rotation.

Temporarily tighten the setscrew No. 4 of the counter knife unit.

9) Put reposition spring **12** on the spring hook. Turn ON the power and air to the sewing machine. Reset the origin.

① Lightly moves up and down
② Lightly moves in the direction of rotation

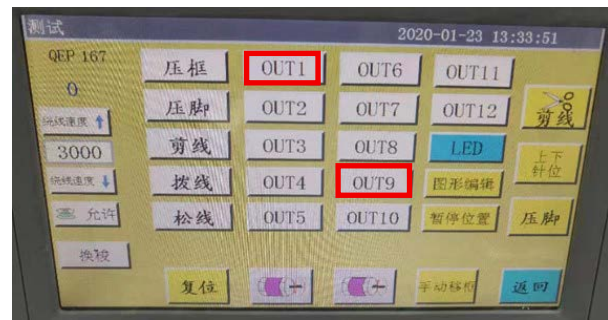
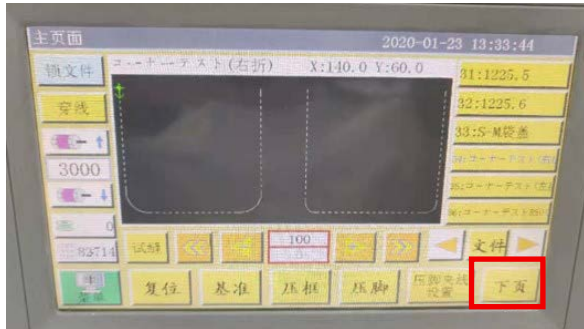

- 10) After resetting, proceed to the next page of the operation panel. ⇒
 Press the "OUT1 (for single-substrate type machine head) / OUT 9 (for double-substrate type machine head)" to bring the tip of the counter knife shaft and that of the moving knife shaft closer to each other while fitting the bushing jig in position. v

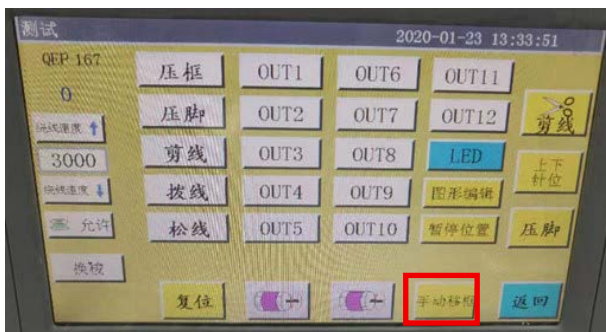

- 11) Press the manual feed. ⇒ , press the "shaft 2+ / shaft 2 -" button to turn the rotary knife for lifting the bushing jig as No. 6. Now, check that the bushing jig freely drops in each of the four directions (0°, 90°, 180°, 270°) and that it rotates smoothly.
 If any malfunction occurs, adjust the position of the counter knife unit.

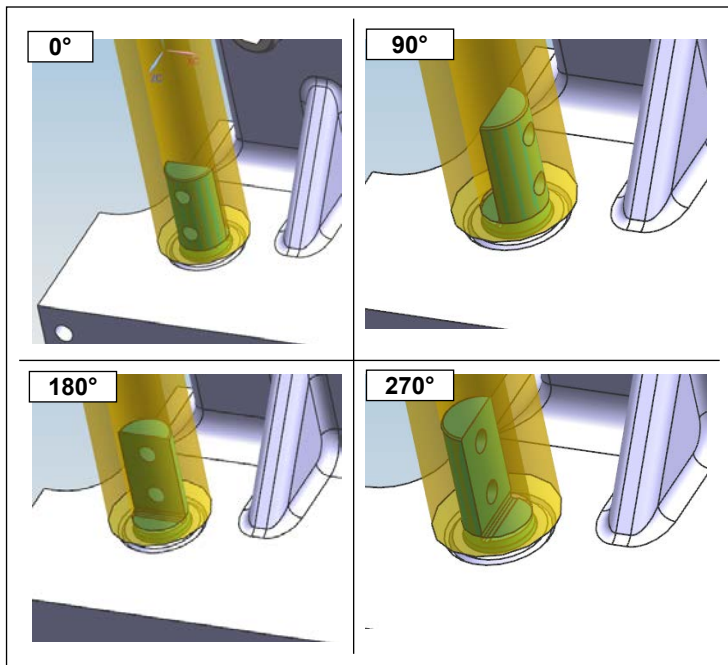

- 12) Check the operation status of the bushing jig respectively in the aforementioned four directions. Then, securely tighten the setscrew No. 4.
 The position of the bushing jig may slightly shift from the adjusted position by securely tightening the setscrew No. 4. It is therefore necessary to check that the bushing jig smoothly rotates in the aforementioned four directions respectively.

Caution Longer service life of the moving knife and counter knife is ensured provided that the maintenance workers from the manufacturer or the maintenance workers who have been trained with the related technology adjust the knife pressure optimally.

6-2-3 How to adjust the timing belt tension

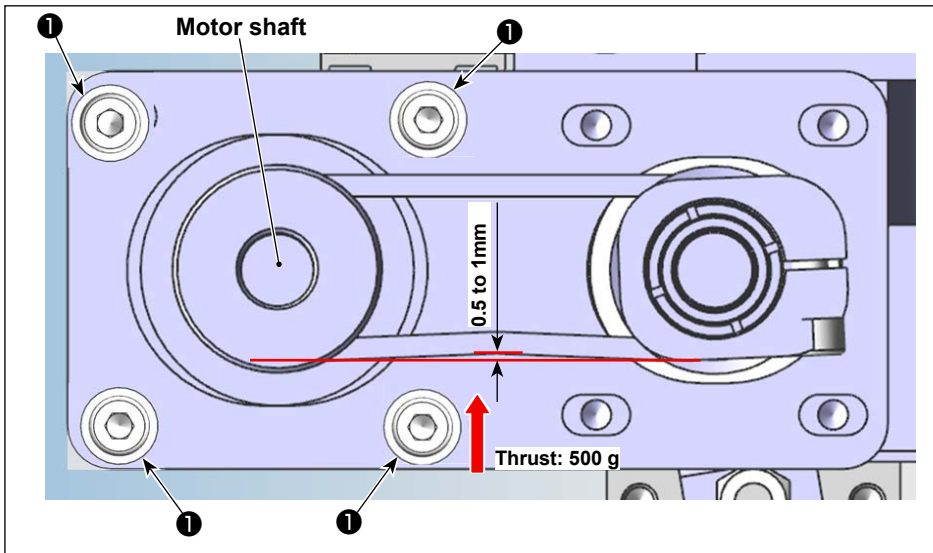

Measure the belt tension with a thrust meter and a pair of vernier calipers. If the belt tension falls out of the specification, loosen motor fixation screws ① (four pieces) and adjust the position of the motor appropriately.

6-2-4 How to adjust the knife pressure

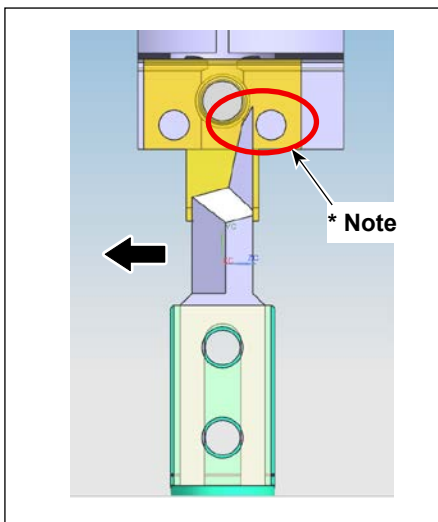

6-2-4-1. Adjusting the mounting position of the moving knife

Install the moving knife vertically while shifting it toward the blade portion (in the direction of the arrow) so as to prevent the blade portion of the moving knife from coming in contact with the knife pressure adjustment screw of the counter knife.

*Note: Do not allow the moving knife to interfere with the screw.

6-2-4-2. Adjusting the direction of installation of the moving knife

Turn ON the power and air to the sewing machine. Reset the origin.

Shift setscrew ③ of the moving knife toward the far side of the sewing machine. Check to make sure that the moving knife is in parallel to the end face of the unit by observing the scale marks of scale ② .

If the moving knife is not in parallel with the end face of the unit, adjust the parallelism between them by loosening clamp screws ① .

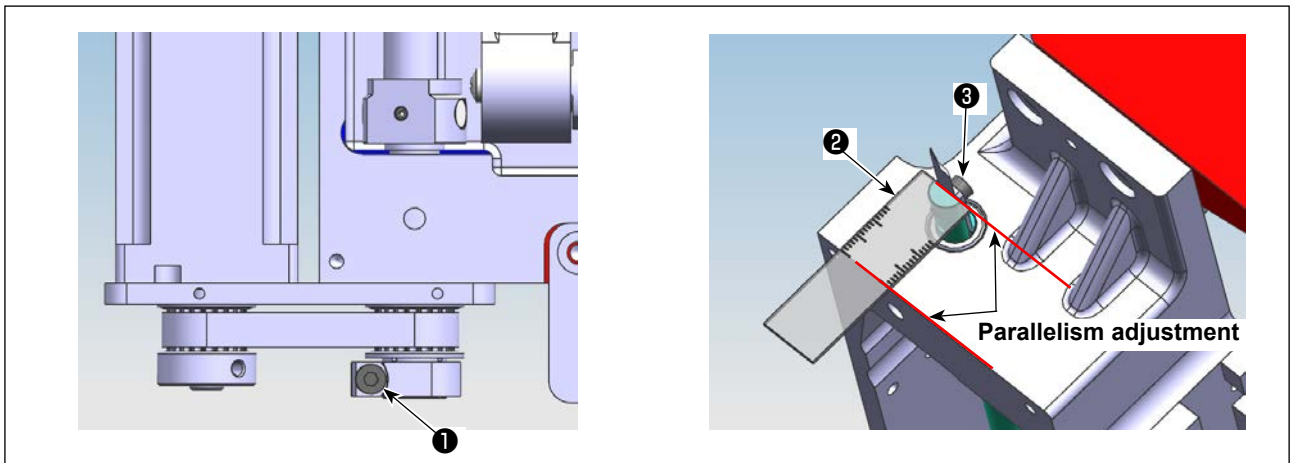

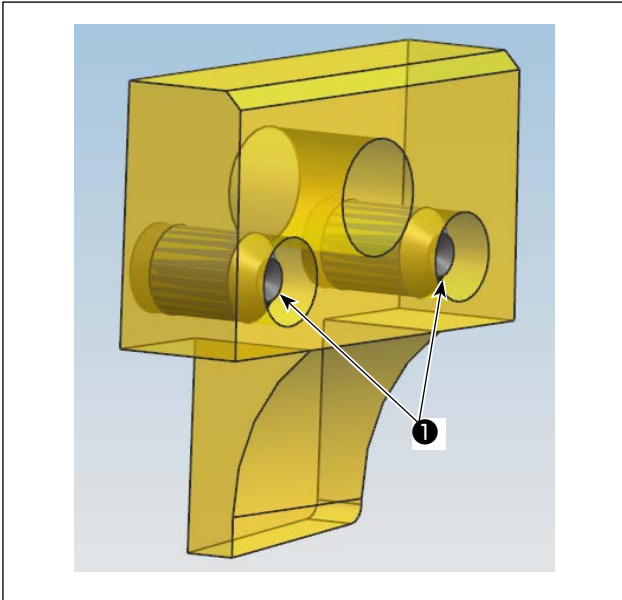

6-2-4-3. Position of the knife pressure adjustment screw of the counter knife

Adjust the position of the knife pressure adjustment screw so that it does not protrude the end face of the counter knife.

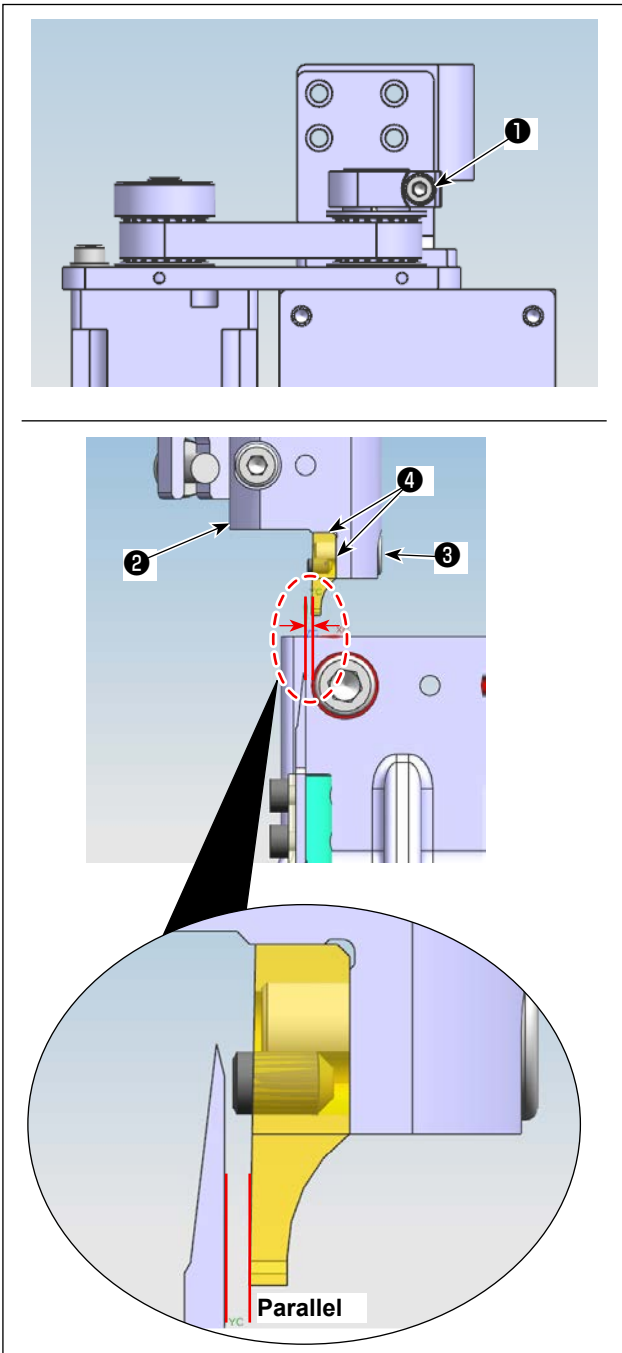

6-2-4-4. Position of the knife pressure adjustment screw of the counter knife

Temporarily tighten setscrew **3** to allow the counter knife to be pressed against two portions **4** of mounting base **2**.

Loosen connection screw **1**. Turn the counter knife shaft by hand to adjust so that the counter knife is almost in parallel with the moving knife.

Under the operation panel manual mode, press the OUT1 (before the port change) / OUT9 (after the port change) button to place it in the ON state. Bring the moving knife closer to the counter knife. Adjust the parallelism between them.

Under the operation panel manual mode, press the "OUT1 (before the port change) / OUT9 (after the port change)" button to place it in the ON state. Bring the moving knife closer to the counter knife. Adjust the parallelism between them.



6-2-4-5. Adjustment of the height of the counter knife and moving knife

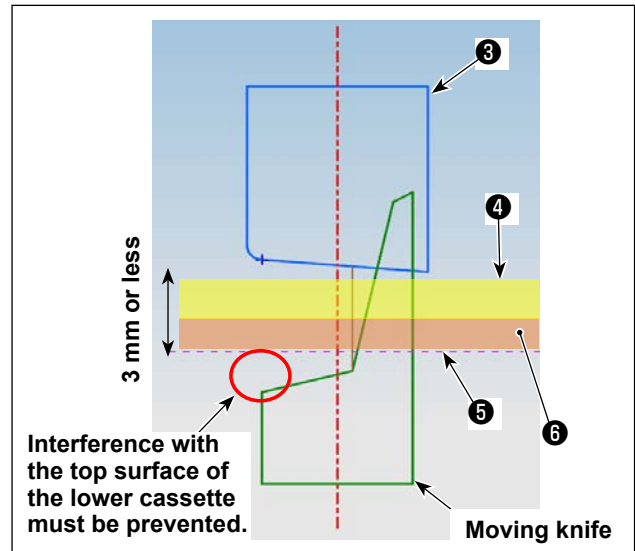
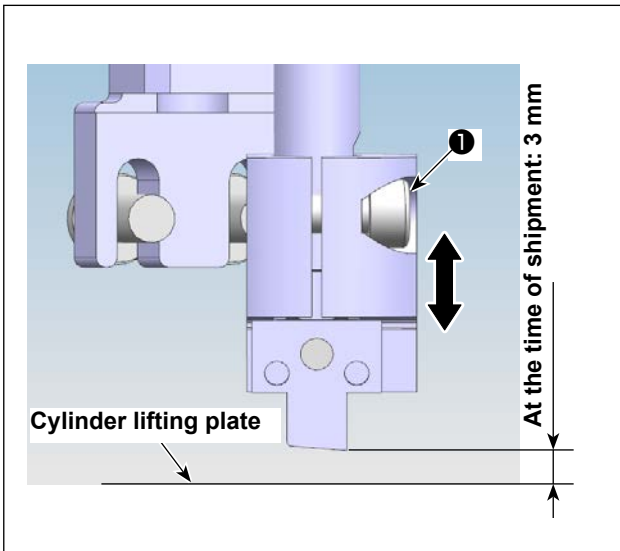

- 1) Loosen setscrews ① and ② of the counter knife base. Adjust the height of the counter knife.
- 2) In the normally shipped state, the sewing machine has been factory-adjusted so that the height of the blade point (lower end point) of the counter knife is 3 mm above the top surface of lifting plate ⑤ .
If the total thickness of material ④ and lower cassette ⑥ is 3 mm or less, adjustment of the height of counter knife ③ will not be necessary.
If this total thickness exceeds 3 mm, it will be necessary to adjust the height of counter knife ③ . (Up to 5.5 mm)

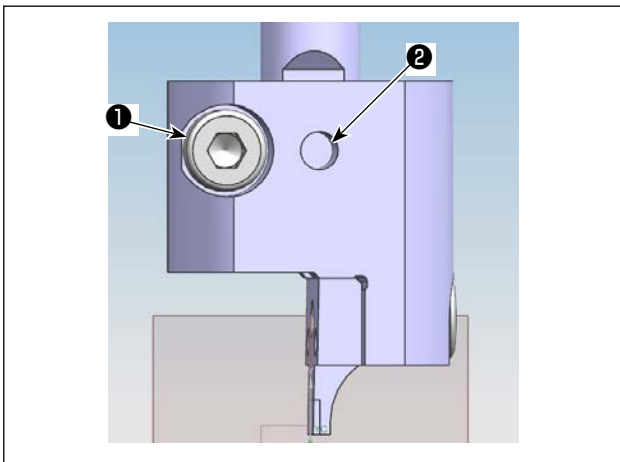

- 3) After you have adjusted the counter knife to an appropriate height, tighten first setscrew ② so that it is flush with the flat part of the counter knife shaft. Then, tighten setscrew ① .
(Fix setscrew ② on the flat part of the counter knife shaft.)

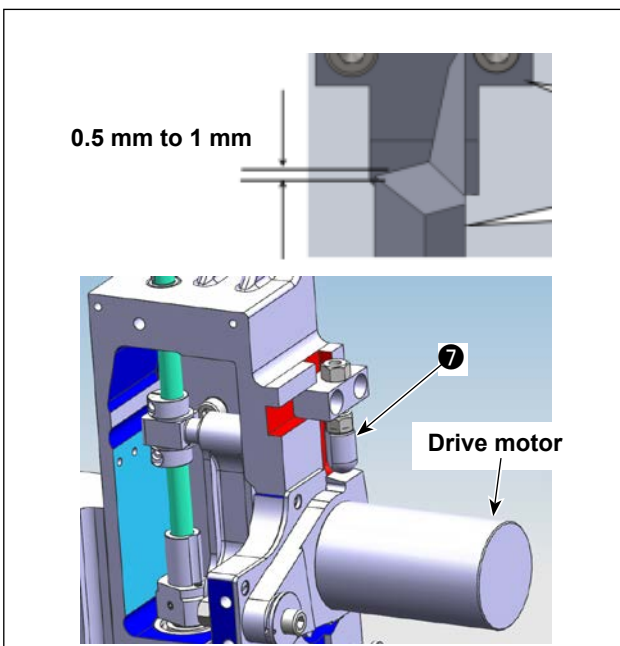

- 4) After you have adjusted the height of the counter knife, adjust the height of drive motor lifting stopper ⑦ so that the engagement amount between the moving knife and the counter knife is 0.5 to 1 mm.

Lifting the drive motor by hand, check to make sure that the square portion of the moving knife blade does not interfere with the top surface of the lower cassette when the moving knife is at its lower dead point.

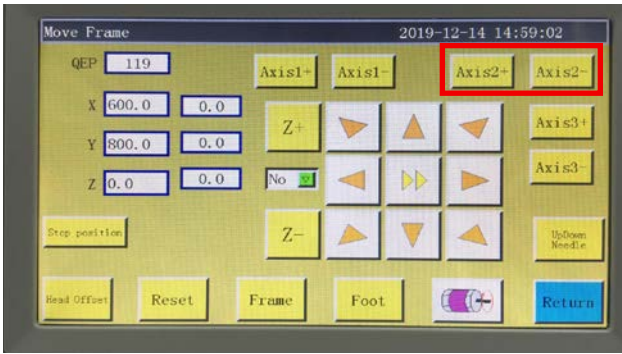

6-2-4-6. Adjusting the knife pressure

Under the manual mode, press the axis 2 button.

Turn the knife to change its direction so as to allow easy adjustment.

Push a hexagonal wrench key into the slot in the set-screw (in the direction of the left arrow) and loosen the setscrew until the counter knife is aligned with the moving knife while lifting the setscrew in the direction of the up arrow to allow the counter knife to be pressed against the mounting base.

After you have loosened the setscrew, push the adjustment screw keeping the setscrew held loosened.

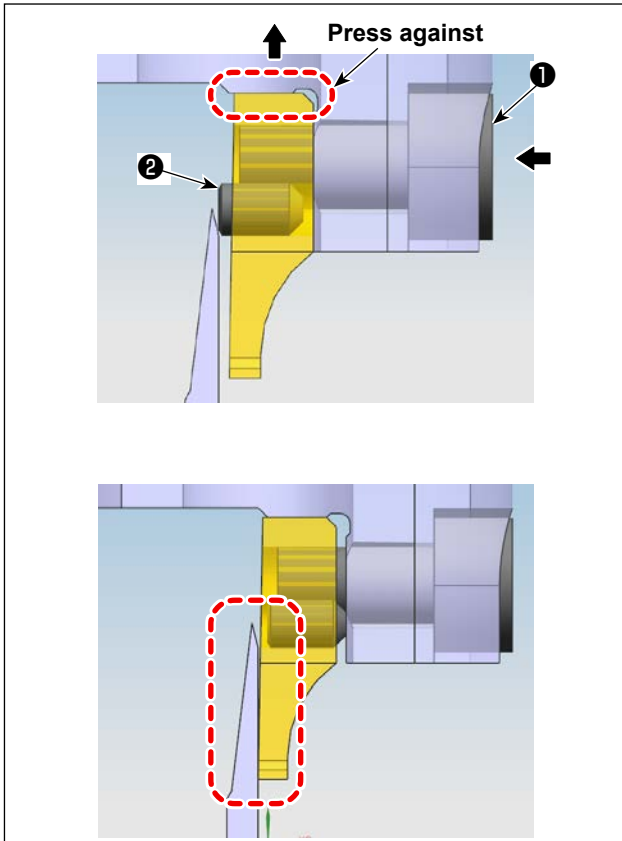

Caution Target knife pressure is 0 (zero). (So that the moving knife comes in slight contact with the counter knife)

After you have pushed the adjustment screw, tighten the setscrew.

Adjust the counter knife and the moving knife until they are aligned well with each other.

6-2-4-7. Cutting test

After you have adjusted the knife pressure, try to cut the material.

If the knife fails to cut the material, it will be necessary to re-adjust the knife pressure to a slightly higher value than the adjustment value given in [\[6-2-4-6. Adjusting the knife pressure\]](#) p.71.

Caution In order to ensure the service life of the moving knife and counter knife, it is recommended that a profession engineer carries out adjustment of the knife pressure so as to adjust the knife pressure to the best-suited value.

6-2-5. Changing the moving knife

Loosen two screws (rotary moving knife parts catalog number 53) on the moving knife. Detach the moving knife and change it with a new one. Then, tighten the aforementioned two screws. When you attach a moving knife, take care to attach it so that its bottom portion comes in contact with the moving knife rod without fail.

6-2-6. Adjusting the operating speed of template when the knife operates

Start the machine and proceed to the main interface. Then, click "Menu" ①. Click "Param File" ②, "Speed param" ③, and click the "Next" ④. Then, adjust the "Head 2 speed (mm/s)" parameter value as shown in ⑤. When you want to adjust the related parameter(s), contact the manufacturer or the professional worker who is an expert on the related technology (The Head 2 speed has been factory-set to 40 mm/s at the time of shipment).

6-2-7. Usage instructions

6-2-7-1. Creating patterns

When you want to create a knife pattern, take care to ensure that the shortest distance of 3 mm or more is provided from the knife locus line to the seam line. Sewing patterns are created using the Layer 1, and knife patterns are created using the Layer 2.

6-2-7-2. Installing the sewing software

Open the exclusive rotary knife sewing software. Select the file and click it to open. Select the file you want to edit. Set a graphic of the knife you want to use to the Layer 2 (as shown in Fig. 1). Double-click on Layer 2 to open the interface (as shown in Fig. 2). Change the Head 1 with the Head 2. Then, confirm with a click on the OK button to complete the procedure.

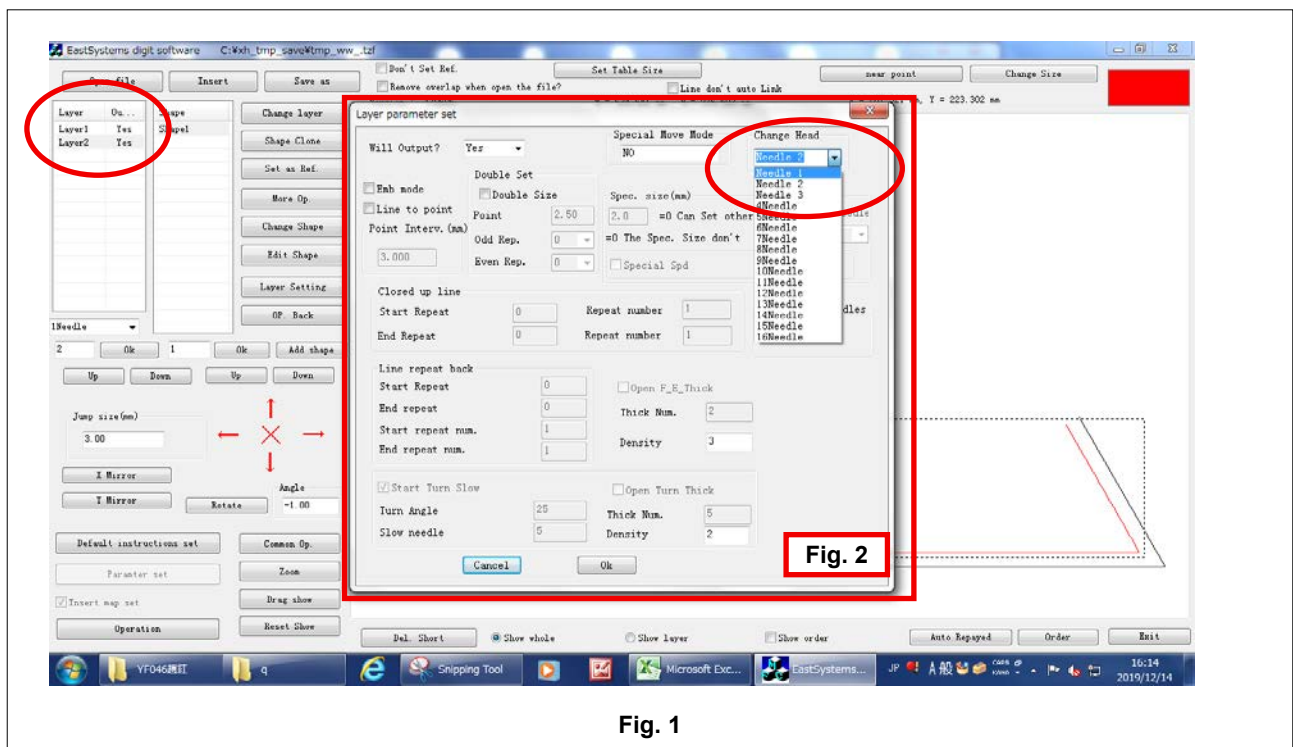
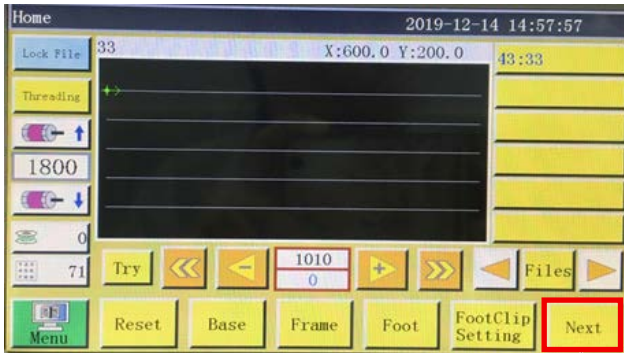

Fig. 1

6-2-7-3. Setting the references



1

Start the machine and proceed to the main interface. Then, click "Next" ①. Click "Move frame" ②, "Head Offset" ③, and the "Head 2 displacement". Enter "98.5" in the X-axis direction field and "54.5" in the Y-axis direction field (The head 2 position should be adjusted according to the cutting position and the displacement of sewing position. The smaller the X-axis travel amount is entered, the more the knife position is moved to the left. The smaller the Y-axis travel amount is entered, the closer the sewing position that faces to the knife position is brought to the work position).

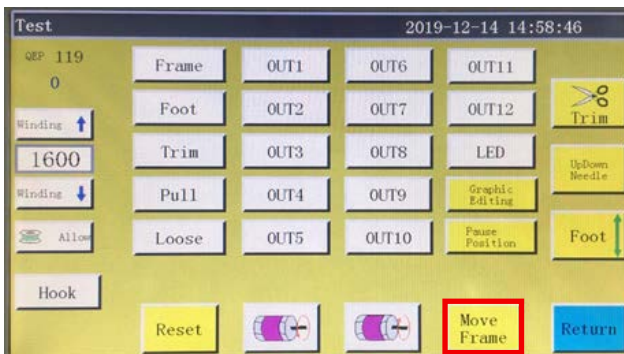

2

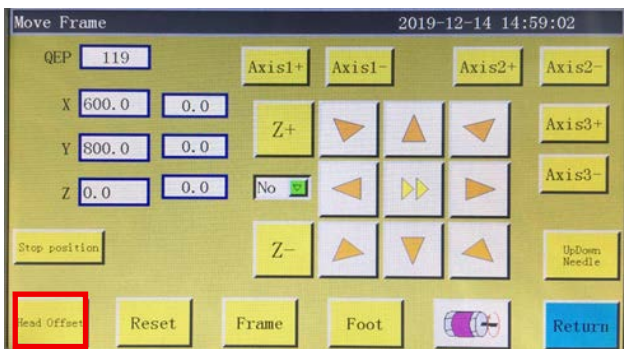

3

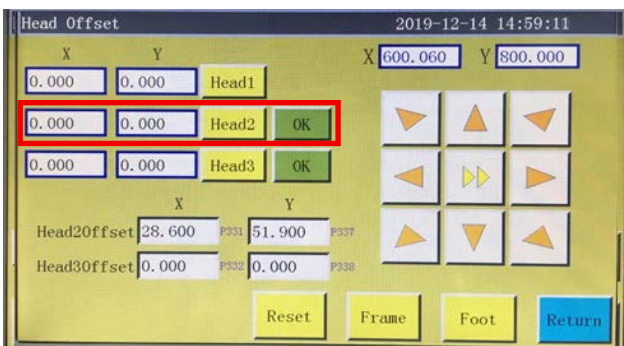

6-2-8. Definition of the electrical control buttons

- OUT9 Lifting / lowering of the rotary counter knife / moving knife
- OUT11 Starting the cutting operation of the rotary moving knife
- OUT12 Lifting / lowering of the clamp foot of the rotary counter knife

6-2-9. Function-related precautions

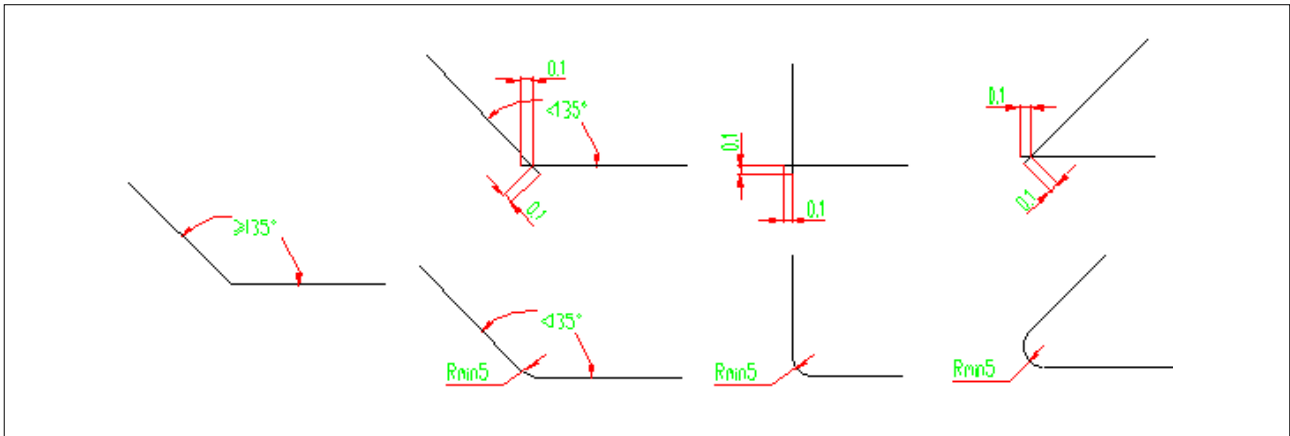

1. Do not cut a graphic that has a corner R of which is less than 5 (radius is less than 5 mm)
2. When cutting a graphic that has no corner with an excessive R, it is possible to cut it without interrupting the cutting operation at connection points provided that the angle is 135° or more. If the angle is less than 135° , the connection points intersect with each other at the position that is 0.1 mm ahead of them (as shown in the figure).
3. From the beginning to the end of cutting, cutting effect will be maximized by extending or shortening the cutting lines according to the specific effect of cutting. (Extend or shorten the length of cutting lines when cutting a graphic)